

# 12' x 12' MERIDIAN GAZEBO

with ALUMINUM ROOF

Installation and Operating Instructions – YM11769



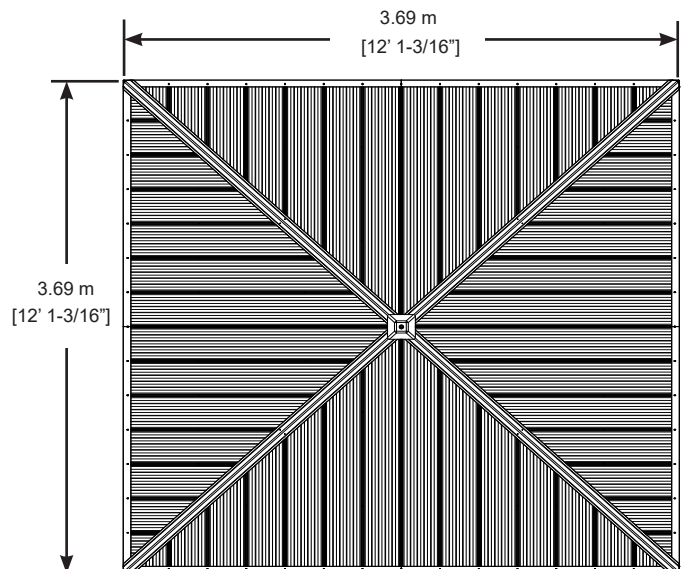
HEIGHT:  
10'6" or 3.2m

Revised 04-22-2021

**YARDISTRY**

Yardistry – North America  
Toll Free Customer Support:  
1.888.509.4382

info@yardistrystructures.com  
www.yardistrystructures.com



## **Important Safety Notice!**

Yardistry components are intended for privacy, decorative and ornamental use only.

### **Product is NOT INTENDED for the following:**

- A safety barrier to prevent unsupervised access to pools, hot tubs, spas or ponds.
- As load bearing support for a building, structure, heavy objects or swings.
- Used in structures that trap wind, rain or snow that would create extra load on the product.

### **Accumulated snow must be removed from roof.**

**DO NOT** climb or walk on roof for any reason.

**Permanent structures may require a building permit.** As the purchaser and or installer of this product you are advised to consult local planning, zoning and building inspection departments for guidance on applicable building codes and/or zoning requirements.

**Wood is NOT flame retardant and will burn.** Grills, fire pits and chimineas are a fire hazard if placed too close to a Yardistry structure. Consult user's manual of the grill, fire pit or chimenea for safe distances from combustible materials.

**Wear gloves to avoid injury** from possible sharp edges of individual elements before assembly.

**During installation, follow all safety warnings provided with your tools and use OSHA approved safety glasses.** Some structures may require two or more people to install safely.

**Check for underground utilities before digging or driving stakes into the ground!**

**It is important during assembly to closely follow the instructions,** complete the assembly on a solid level surface and that you follow the instruction to square up, level and anchor the structure, this will reduce the gap at wood connections during assembly.

## **General Information**

**General Information:** Wood components are manufactured with Cedar (C. Lanceolata) which is protected with factory applied water-based stain. Knots, small checks (cracks) and weathering are naturally occurring and do not affect the strength of the product. Annual application of a water-based water repellent sealant or stain is important and will help reduce weathering and checks.

**[www.yardistrystructures.com](http://www.yardistrystructures.com)**

Questions?

Call toll free or write us at:

1 (888) 509-4382

[info@yardistrystructures.com](mailto:info@yardistrystructures.com)

Patents Pending

# Limited Warranty

Yardistry warrants that this product is free from defect in materials and workmanship for a period of one (1) year from the original date of purchase. In addition, for any product with lumber, all lumber is warranted for five (5) years against rot and decay. This warranty applies to the original owner and registrant and is non-transferable.

Regular maintenance is required to assure the integrity of your product and is a requirement of the warranty. This warranty does not cover any inspection costs.

## **This Limited Warranty does not cover:**

- Labour for replacement of any defective item(s);
- Incidental or consequential damages;
- Cosmetic defects which do not affect performance or integrity;
- Vandalism; improper use or installation; acts of nature, including but not limited to wind, storms, hail, floods, excessive water exposure;
- Minor twisting, warping, checking or any other natural occurring properties of wood that do not affect performance or integrity.

Yardistry products have been designed for safety and quality. Any modifications made to the original product could damage the structural integrity of the product leading to failure and possible injury. Yardistry cannot assume any responsibility for modified products. Furthermore, modification voids any and all warranties.

**This product is warranted for RESIDENTIAL USE ONLY. Yardistry disclaims all other representations and warranties of any kind, express or implied.**

*This Warranty gives you specific legal rights. You may have other rights as well which vary from state to state or province to province. This warranty excludes all consequential damages, however, some states/provinces do not allow the limitation or exclusion of consequential damages, and therefore this limitation may not apply to you.*

# Instructions for Proper Maintenance

Your Yardistry structure is designed and constructed of quality materials. As with all outdoor products it will weather and wear. To maximize the enjoyment, safety and life of your structure it is important that you, the owner, properly maintain it.

## HARDWARE:

- Check metal parts for rust. If found, sand and repaint using a non-lead paint complying with 16 CFR 1303.
- Inspect and tighten all hardware after completion of assembly; after first month of use; and then annually. Do not over-tighten as to cause crushing and splintering of wood.
- Check for sharp edges or protruding screw threads, add washers if required.

## WOOD PARTS:

- Applying a water repellent or stain (water-based) on a yearly basis is important maintenance to maintain maximum life and performance of the product.
- Check all wood members for deterioration, structural damage and splintering. Sand down splinters and replace deteriorated wood members. As with all wood, some checking and small cracks in grain is normal
- Some gapping may occur at some wood connections.

## Assembly Guides

### Tools Required:

- |                                  |                  |                           |
|----------------------------------|------------------|---------------------------|
| • Tape Measure                   | • 8' Step Ladder | • 6' Step Ladder x 2      |
| • Carpenters Level               | • Safety Glasses | • Square                  |
| • Standard or Cordless Drill     | • Adult Helper   | • Ratchet                 |
| • #2 Phillips Bit or Screwdriver | • Safety Gloves  | • 7/16, 1/2 & 9/16 Socket |
| • 7/16" & 9/16" Wrench           | • Hard Hat       |                           |

### Symbols:

Throughout these instructions symbols are provided in the top, right-hand corner of the page.



- Use Help, where this is shown, 2, 3 or 4 people are required to safely complete this step. To avoid injury or damage to the assembly make sure to get some help.



- Use a measuring tape to assure proper location



- Pre-drill a pilot hole before fastening screw or lag to prevent splitting of wood.

**If you dispose of your Yardistry structure:** Please disassemble and dispose of your unit so that it does not create any unreasonable hazards at the time it is discarded. Be sure to follow your local waste ordinances.

## Assembly Tips

Following are some helpful tips to make the assembly process smooth and efficient.

### PRE-ASSEMBLIES:

(i.e. Post and Beam Assemblies, Roof Rafter Assembly, etc)

- Work on a raised, solid and flat surface such as, a table or saw horse.
- Keep all connections flush where shown in the instructions.
- When assembling the beams keep parts flat, straight and snug when connecting.

### METAL PARTS:

- Roofing material may have sharp edges, wear safety gloves.
- Remove all plastic covering, on both sides of the metal panels, directly before installing each piece.
- Place roofing material on a non-abrasive surface before and after assembly as it can bend, dent and scratch easily.
- The roofing screws can easily crush the roof panels and roof edges when using a power drill. We recommend hand tightening the roofing screws so they sit snug and tight to the roofing material.

# Permanent Installation Examples

**Note: It is critically important you start with square, solid and level footings, concrete pad or deck to attach your Pergola Room.**

We supply Post Mounts with this structure which gives you the flexibility to permanently install your structure to a pre-existing or new wood or concrete surface.

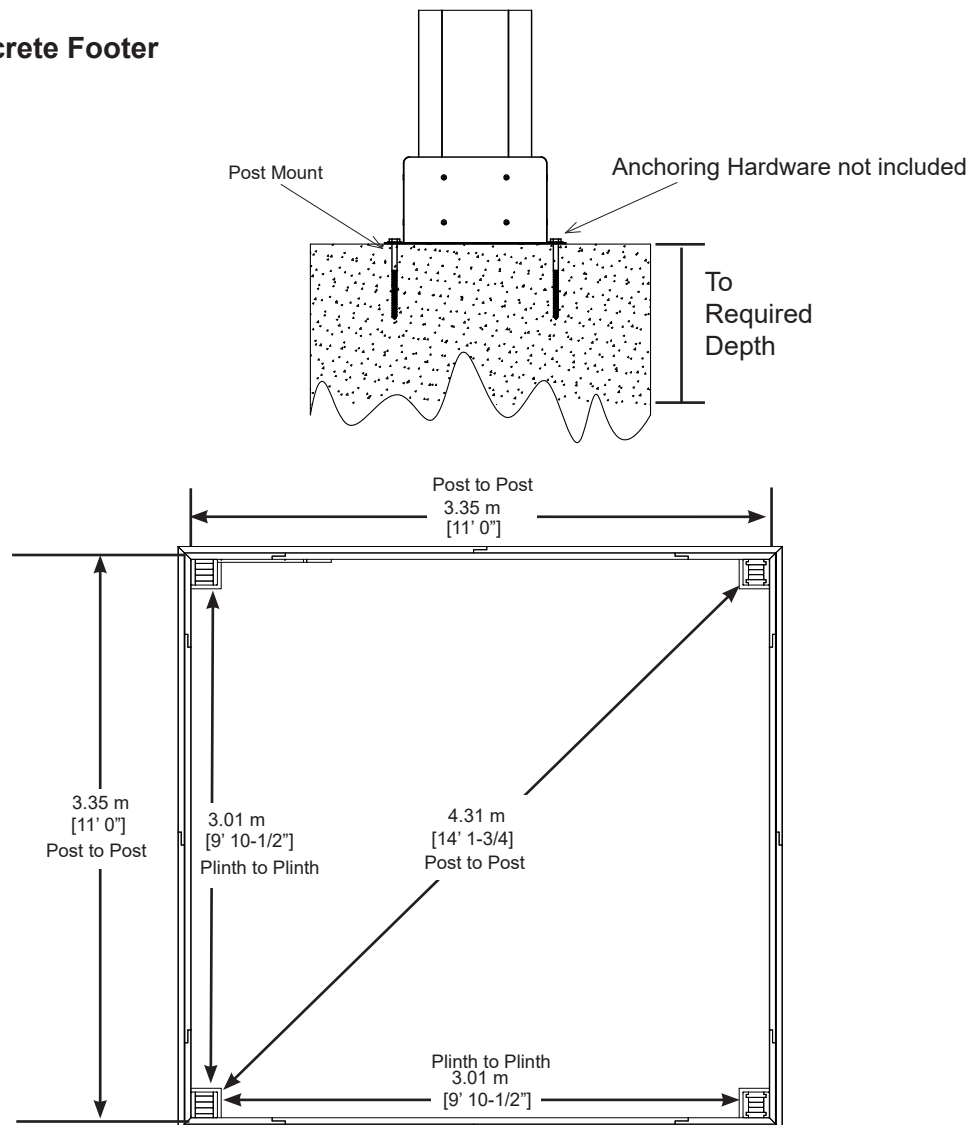
- The hardware to attach the Post Mount to the structure is included.
- The hardware to mount the structure permanently will need to be purchased separately at your local hardware store.

If you are mounting to concrete footers see below for the correct locations and placement. Please double check for possibility of any underground utilities such as gas, telephone, cable or sprinkler lines.

Following are some examples of how to mount the structure to wood or concrete surfaces.

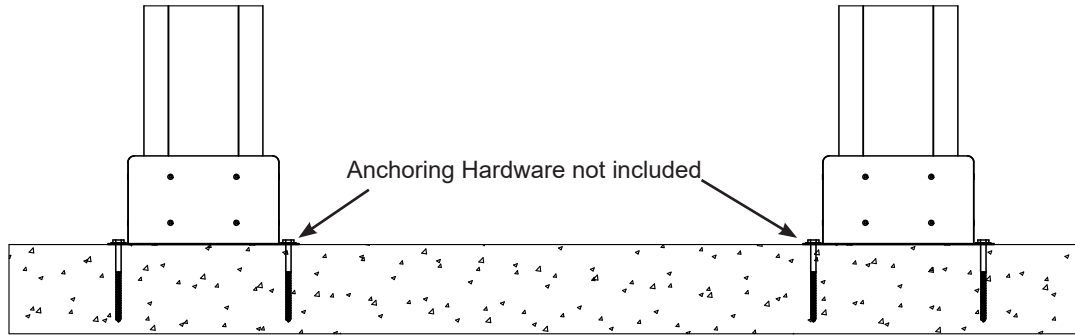
Refer to your local building and city codes, ordinances, neighbourhood covenants, or height restrictions regarding this type of structure for guidance on acceptable installation requirements.

## Concrete Footer

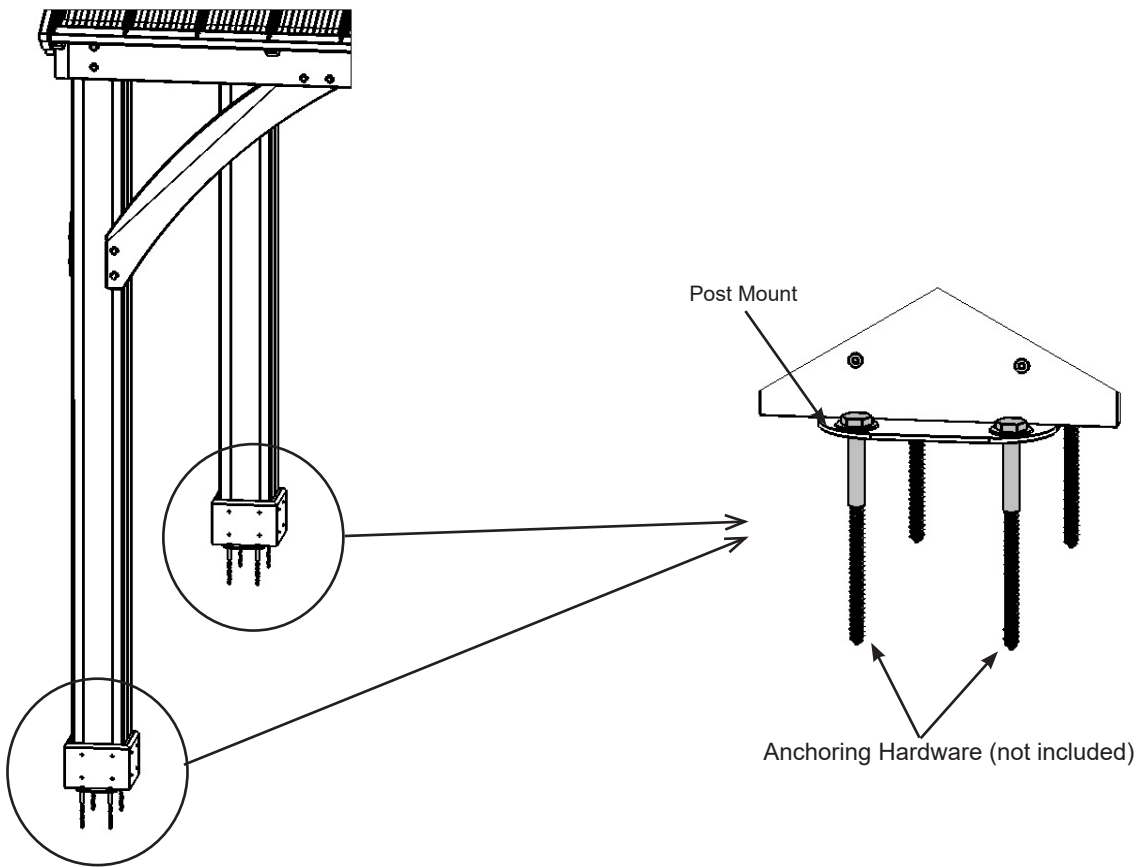
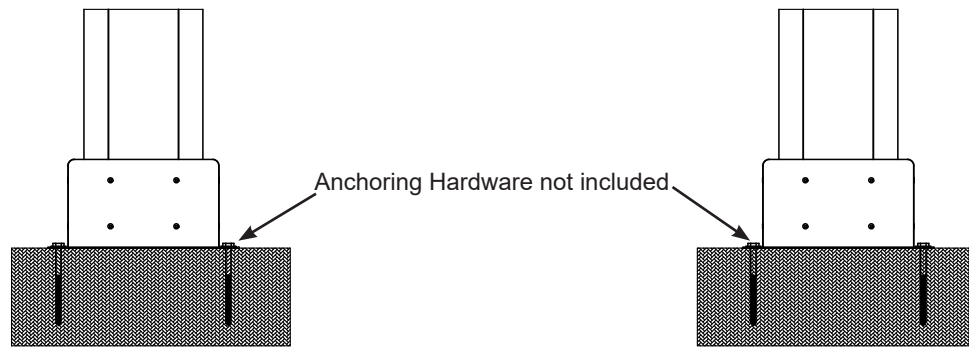


## Permanent Installation Examples cont.

Concrete Patio [min. 3.66 m x 3.66 m (12' x 12')] with 1.83 m (6") clearance on all sides



Wood Deck [min. 3.66 m x 3.66 m (12' x 12')] with 1.83 m (6") clearance on all sides

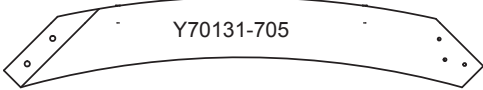


# Part Identification (Dimensions are approximate and are shown to assist in the identification of parts for assembly. Actual dimensions may be smaller or larger.)

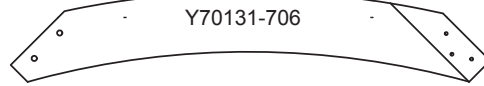
**152.4 x 152.4 x 2336.8mm (6 x 6 x 92")**  
**4pc. (696) - M Post**



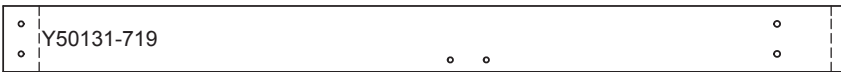
**34.9 x 190.5 x 1015mm (1-3/8 x 7-1/2 x 40")**  
**4pc. (705) - Gusset Right**



**34.9 x 190.5 x 1015mm (1-3/8 x 7-1/2 x 40")**  
**4pc. (706) - Gusset Left**



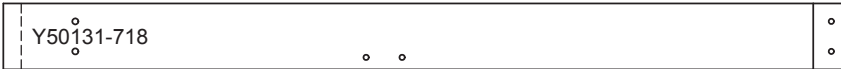
**38.1 x 139.7 x 1790.7mm (1-1/2 x 5-1/2 x 70-1/2")**  
**4pc. (719) - Beam End Right**



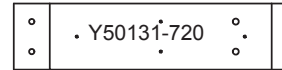
**19.1 x 133.4 x 190.5mm (3/4 x 5-1/4 x 7-1/2")**  
**16pc. (422) - Plinth**



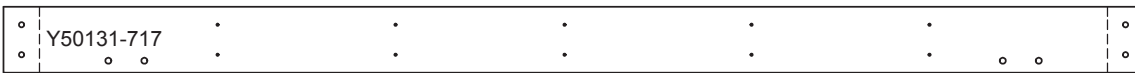
**38.1 x 139.7 x 1790.7mm (1-1/2 x 5-1/2 x 70-1/2")**  
**4pc. (718) - Beam End Left**



**38.1 x 139.7 x 584.2mm (1-1/2 x 5-1/2 x 23")**  
**8pc. (720) - Beam End Short**



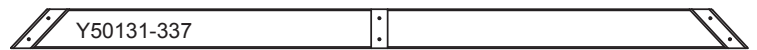
**38.1 x 139.7 x 2413mm (1-1/2 x 5-1/2 x 95")**  
**4pc. (717) - Beam**



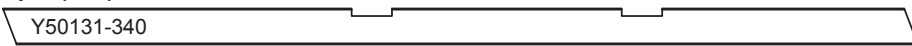
**31.8 x 82.6 x 2628.1mm (1-1/4 x 3-1/4 x 103-7/16")**  
**4pc. (336) - Strap**



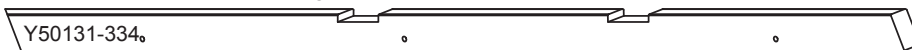
**31.8 x 82.6 x 1561.3mm (1-1/4 x 3-1/4 x 61-7/16")**  
**4pc. (337) - Strap Short**



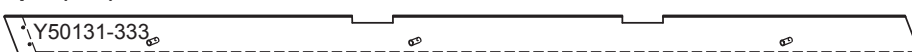
**31.8 x 76.2 x 1937.1mm (1-1/4 x 3-1/4 x 76-1/4")**  
**4pc. (340) - Rafter**



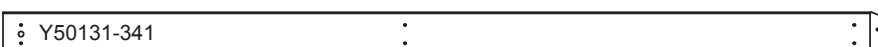
**25.4 x 88.9 x 2631.5mm (1 x 3-1/2 x 103-5/8")**  
**4pc. (334) - Rafter Corner Right**



**25.4 x 88.9 x 2631.5mm (1 x 3-1/2 x 103-5/8")**  
**4pc. (333) - Rafter Corner Left**



**31.8 x 82.6 x 1866.9mm (1-1/4 x 3-1/4 x 73-1/2")**  
**4pc. (341) - Fascia Left**



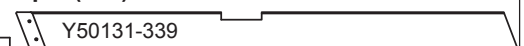
**31.8 x 76.2 x 1062mm (1-1/4 x 3 x 41-13/16")**  
**4pc. (338) - Rafter Short Right**



**31.8 x 82.6 x 1866.9mm (1-1/4 x 3-1/4 x 73-1/2")**  
**4pc. (342) - Fascia Right**

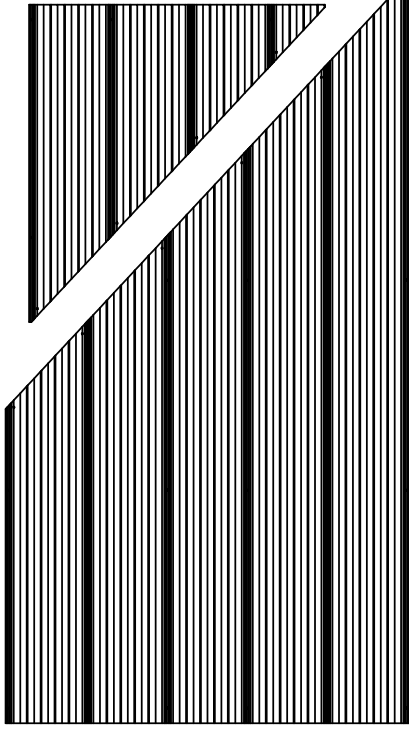
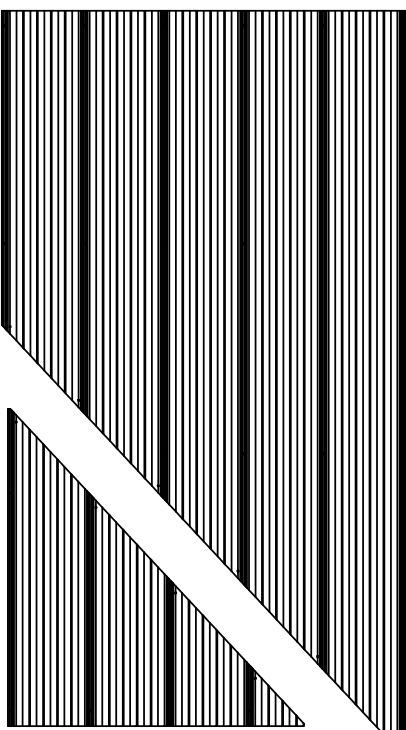





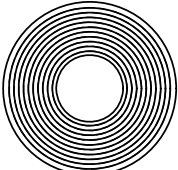

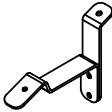
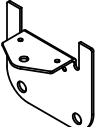
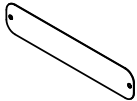





**31.8 x 76.2 x 1062mm (1-1/4 x 3 x 41-13/16")**  
**4pc. (339) - Rafter Short Left**

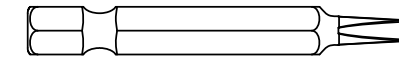
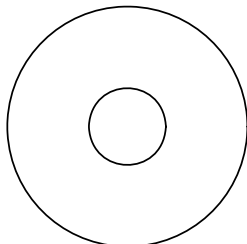
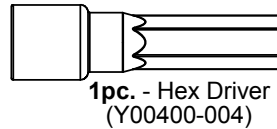
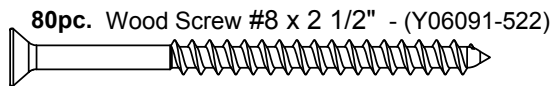
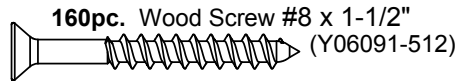
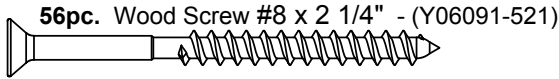
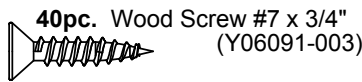
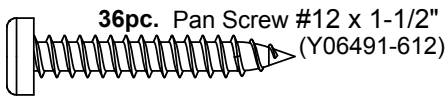
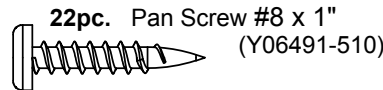
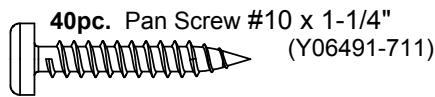
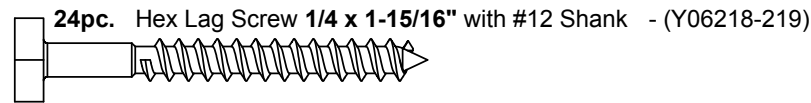
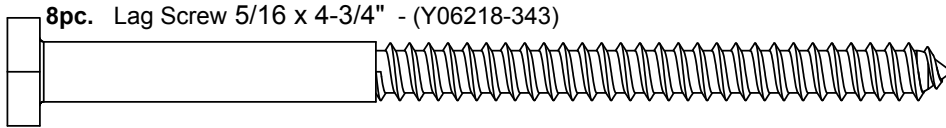
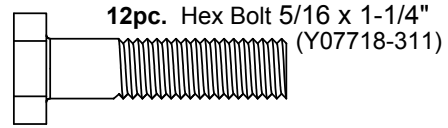
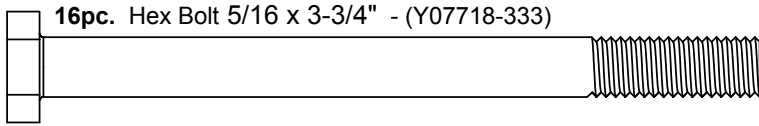
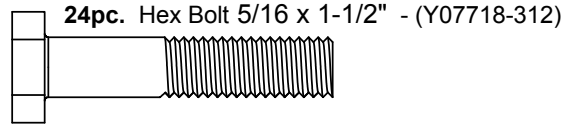
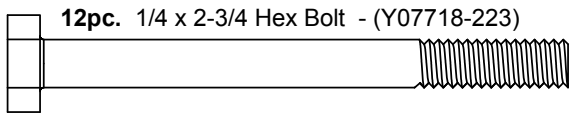




# Hardware Identification ( Dimensions are approximate and are shown to assist in the identification of parts for assembly. Actual dimensions may be smaller or larger. )

<p><b>4pc. - Left Short Panel</b> (Y01033-099)</p>  <p><b>4pc. - Left Long Panel</b> (Y01033-097)</p>	<p><b>4pc. - Right Long Panel</b> (Y01033-098)</p>  <p><b>4pc. - Right Short Panel</b> (Y01033-100)</p>	<p><b>4pc. Ridge Cap Short 25.2</b> (Y01033-132)</p>   <p><b>4pc. Ridge Cap Long 81.5</b> (Y01033-131)</p>
<p><b>1pc. - Roof Panel Set</b> (Y70833-084)</p>		
<p><b>4pc. Roof Edge Left</b> - (Y01033-091)</p> 		
<p><b>4pc. Roof Edge Right</b> - (Y01033-092)</p> 		
<p><b>8pc. Ridge Clip 102.5</b> - (Y01033-133)</p> 		
<p><b>1pc. - Weather Seal - Ridge Clip</b> (8Pk) (Y70818-074)</p> 	<p><b>1pc. - Corner Cap Set</b> (4Pk) (Y70833-103)</p> 	<p><b>1pc. - Roof To Beam Bracket Set</b> (12Pk) (Y70829-151)</p> 
<p><b>1pc. - Post Mount Set</b> (8Pk) (Y70819-109)</p> 	<p><b>1pc. - Gazebo ID Plaque</b> (Y70800-104)</p> 	<p><b>1pc. Peak Cap</b> (Y01033-095)</p> 
<p><b>2pc. - 50mm Hook</b> (Y00418-050)</p> 	<p><b>1pc. - Roof To Post Bracket Set</b> (4Pk) (Y70829-070)</p> 	<p><b>1pc. Carriage Bolt</b> (Y07490-260)</p> <p><b>1pc. Spring Clip</b> (Y09490-001)</p> <p><b>1pc. 1/4" Nut</b> (Y08490-200)</p> <p><b>2pc. Roof Peak Bracket</b> (Y00429-068)</p> <p><b>1pc. Peak Loop</b> (Y20018-003)</p>

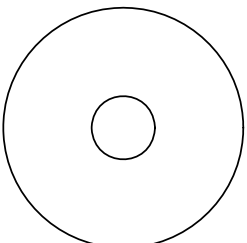
# Hardware Identification ( Dimensions are approximate and are shown to assist in the identification of parts for assembly. Actual dimensions may be smaller or larger. )



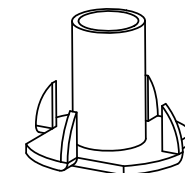
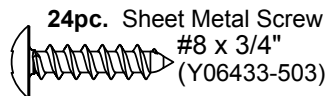
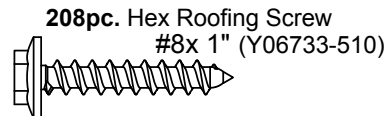
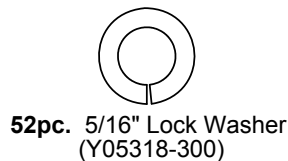
16pc.  
3/8 x 1-1/4" Large Washer  
(Y05118-811)



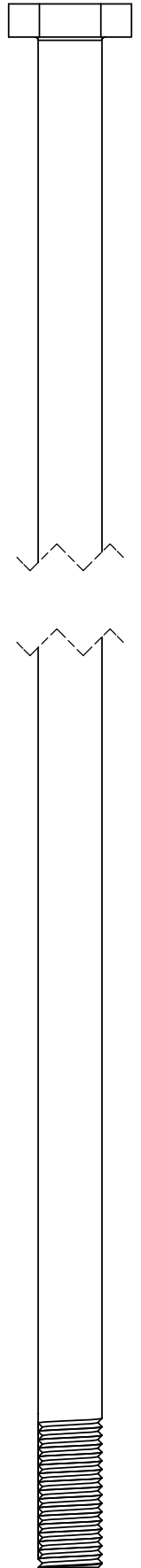
1pc. #2 x 2" Robertson Driver (Y00400-005)



108pc.  
1/4-5/16 x 1-1/4" Large Washer  
(Y05118-311)

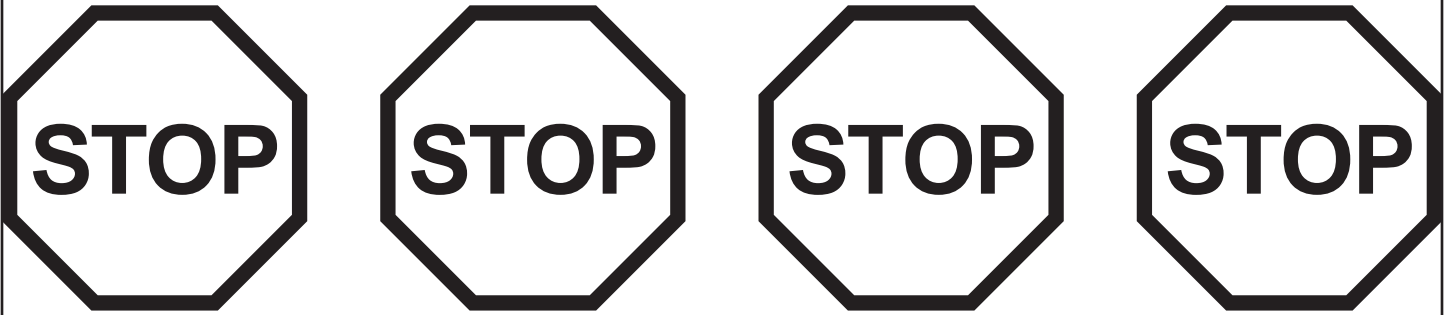


52pc. 5/16 - T-Nut  
(Y08518-300)



8pc. Hex Bolt  
3/8 x 9-1/2"  
(Y07718-892)

# Step 1: Inventory Parts - Read This Before Starting Assembly



- A.** This is the time for you to inventory all your hardware, wood and accessories, referencing the parts identification sheets. This will assist you with your assembly.
- Each step indicates which bolts and/or screws you will need for assembly, as well as any flat washers, lock washers, t-nuts or lock nuts.
- B.** If there are any missing or damaged pieces or you need assistance with assembly please contact the consumer relations department directly. Call us before going back to the store.

**1-888-509-4382**

**support@yardistrystructures.com**

- C.** Read the assembly manual completely, paying special attention to ANSI warnings; notes; and safety/maintenance information on pages 1 - 4.
- Follow the instructions in order.
  - This structure is designed to be assembled and installed ideally by four people, DO NOT attempt to install alone.
  - Consider the slope of elevation where you plan to install the structure. Also, check for gas, telephone, other utilities or sprinkler line locations prior to excavating any holes.
- D.** Before you discard your cartons fill out the form below.
- The carton I.D. stamp is located on the end of each carton.
  - Please retain this information for future reference. You will need this information if you contact the Consumer Relations Department.

**PRODUCT NUMBER: YM11769**

CARTON I.D. STAMP: \_ \_ \_ \_ \_ (Box 1)

CARTON I.D. STAMP: \_ \_ \_ \_ \_ (Box 2)

CARTON I.D. STAMP: \_ \_ \_ \_ \_ (Box 3)

## Step 2: Post Assemblies

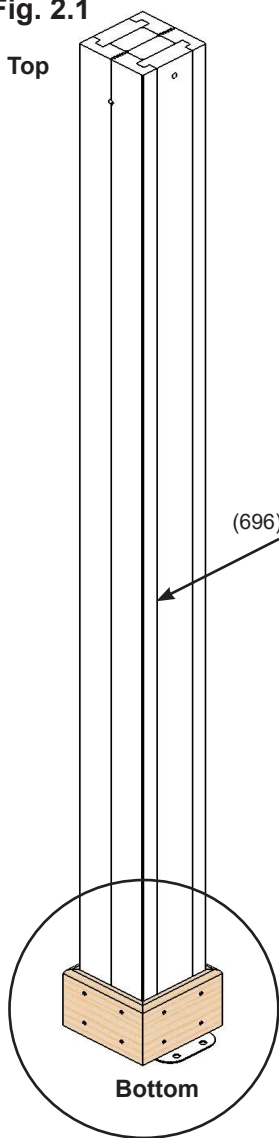
**A:** At the bottom of each (696) M Posts insert two 5/16" T-Nuts as shown in fig. 2.1 and 2.2.

**B:** At the bottom of each (696) M Post place two Post Mounts tight to the bottom and inside faces as shown in fig. 2.1 and 2.2. Loosely attach with one 5/16 x 1-1/4" Hex Bolt (with 5/16" lock washer and 1/4-5/16" large washer) per mount so they connect to the T-Nuts.

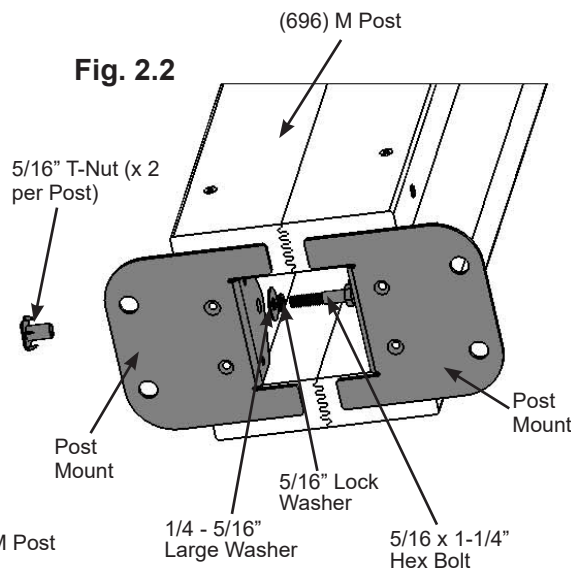
**C:** On each side of the Posts, place one (422) Plinth flush to the bottom and attach with four #8 x 1-1/2" Wood Screws per plinth. Rounded edges on top. (fig. 2.1 and 2.3)

**D:** From the bottom of each Post Mount attach to posts with two #8 x 1-1/2" Wood Screws per mount and then from the inside with two #10 x 1-1/4" Pan Screws per mount. These screws are installed at a slight angle. Tighten all bolts. There will be four M Post Assemblies. (fig. 2.4)

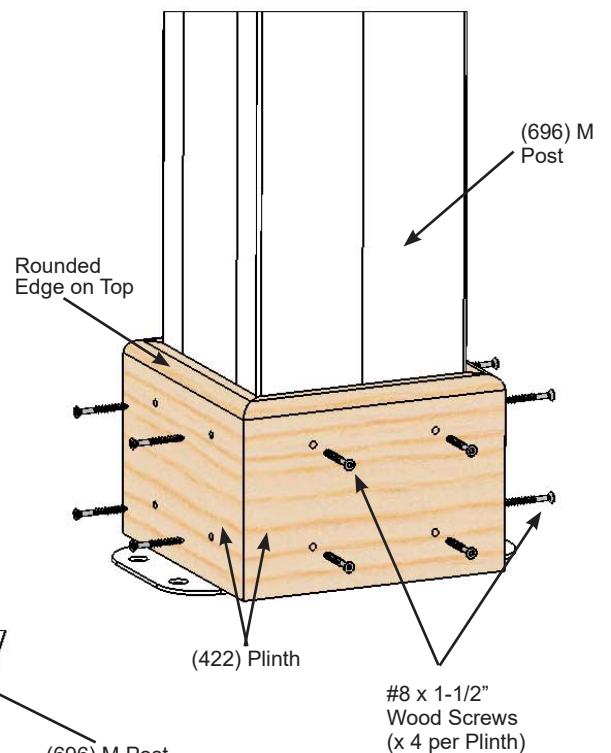
**Fig. 2.1**



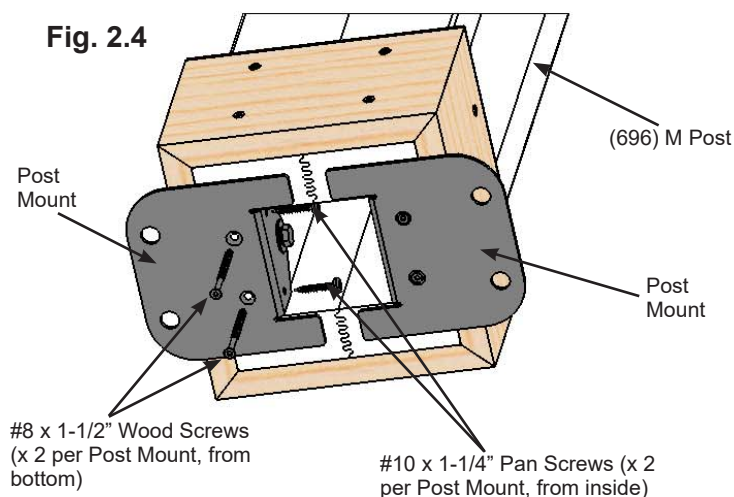
**Fig. 2.2**



**Fig. 2.3**



**Fig. 2.4**



### Wood Parts

4 x (696) M Post  
16 x (422) Plinth

### Hardware

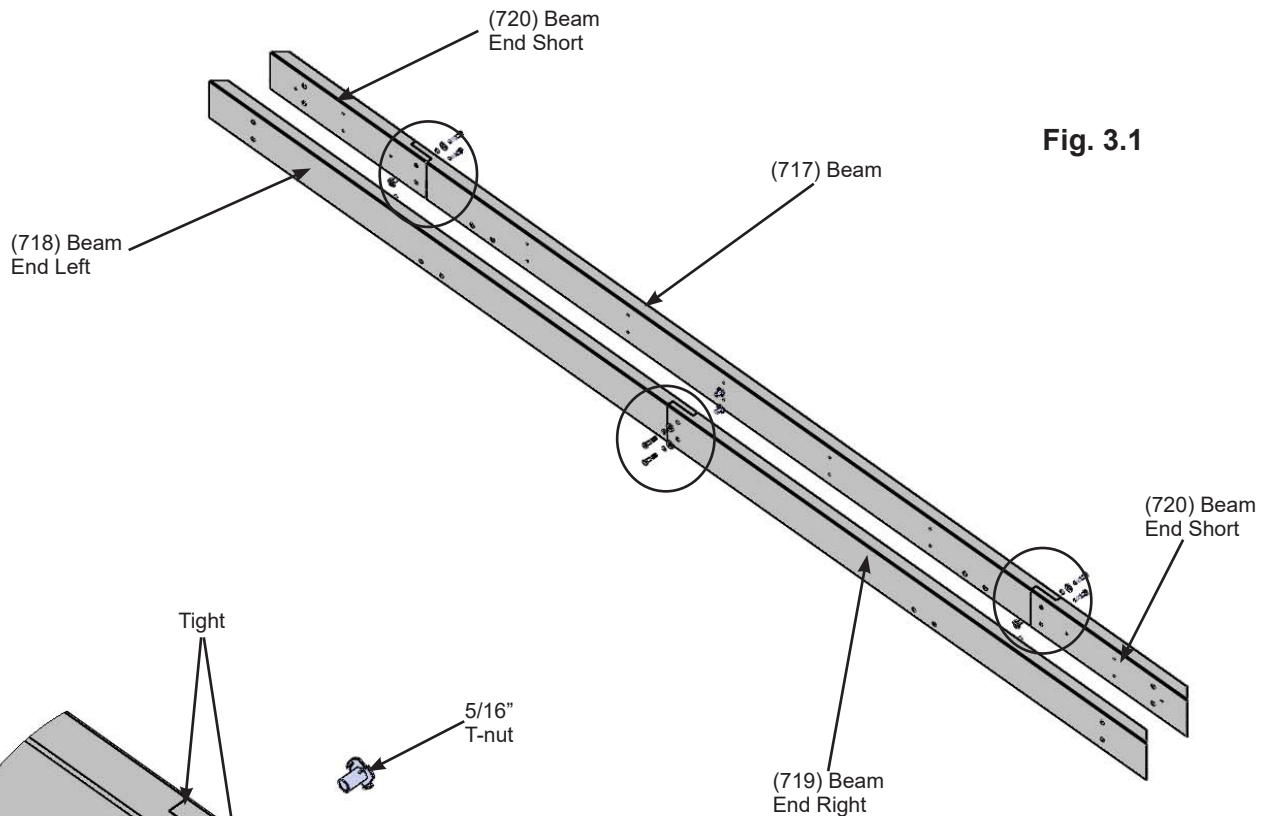
16 x #10 x 1-1/4" Pan Screw  
80 x #8 x 1-1/2" Wood Screw  
8 x Post Mount  
8 x 5/16" T-Nut  
8 x 5/16 x 1-1/4" Hex Bolt  
(with 5/16" lock washer, 1/4-5/16" large washer)

# Step 3: Beam Assembly Part 1

**A:** Connect one (718) Beam End Left and one (719) Beam End Right using two 5/16 x 1-1/2" Hex Bolts (with 5/16" lock washer, 1/4 - 5/16" large washer and 5/16" t-nut) as shown in fig. 3.1 and 3.2.

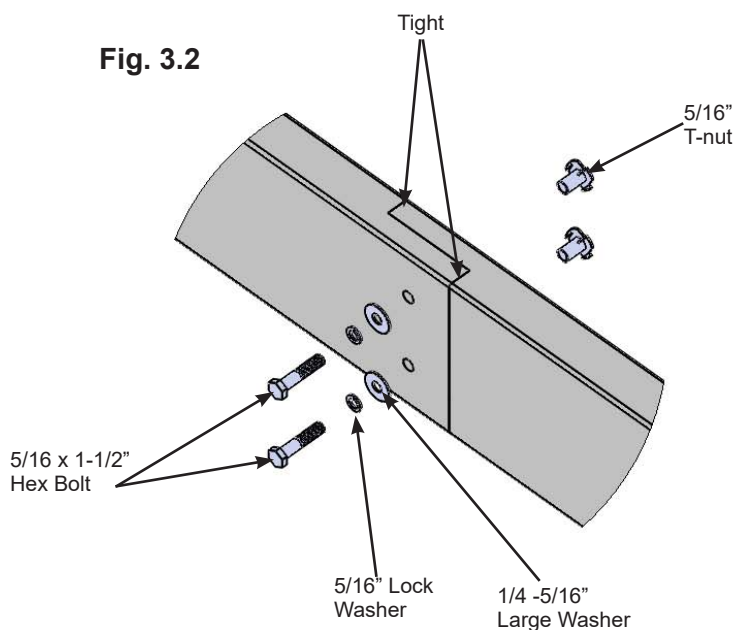
**B:** Connect one (720) Beam End Short to each end of one (717) Beam using two 5/16 x 1-1/2" Hex Bolts (with 5/16" lock washer, 1/4 - 5/16" large washer and 5/16" t-nut) per end as shown in fig. 3.1 and 3.2.

**C:** Repeat Steps A and B three more times to make four Beam Short Assemblies and four Beam End Assemblies.



**Fig. 3.1**

**Fig. 3.2**



***Make sure bolt heads are on the outside of each Beam Assembly***

### Wood Parts

- 4 x (718) Beam End Left
- 4 x (719) Beam End Right
- 8 x (720) Beam End Short
- 4 x (717) Beam

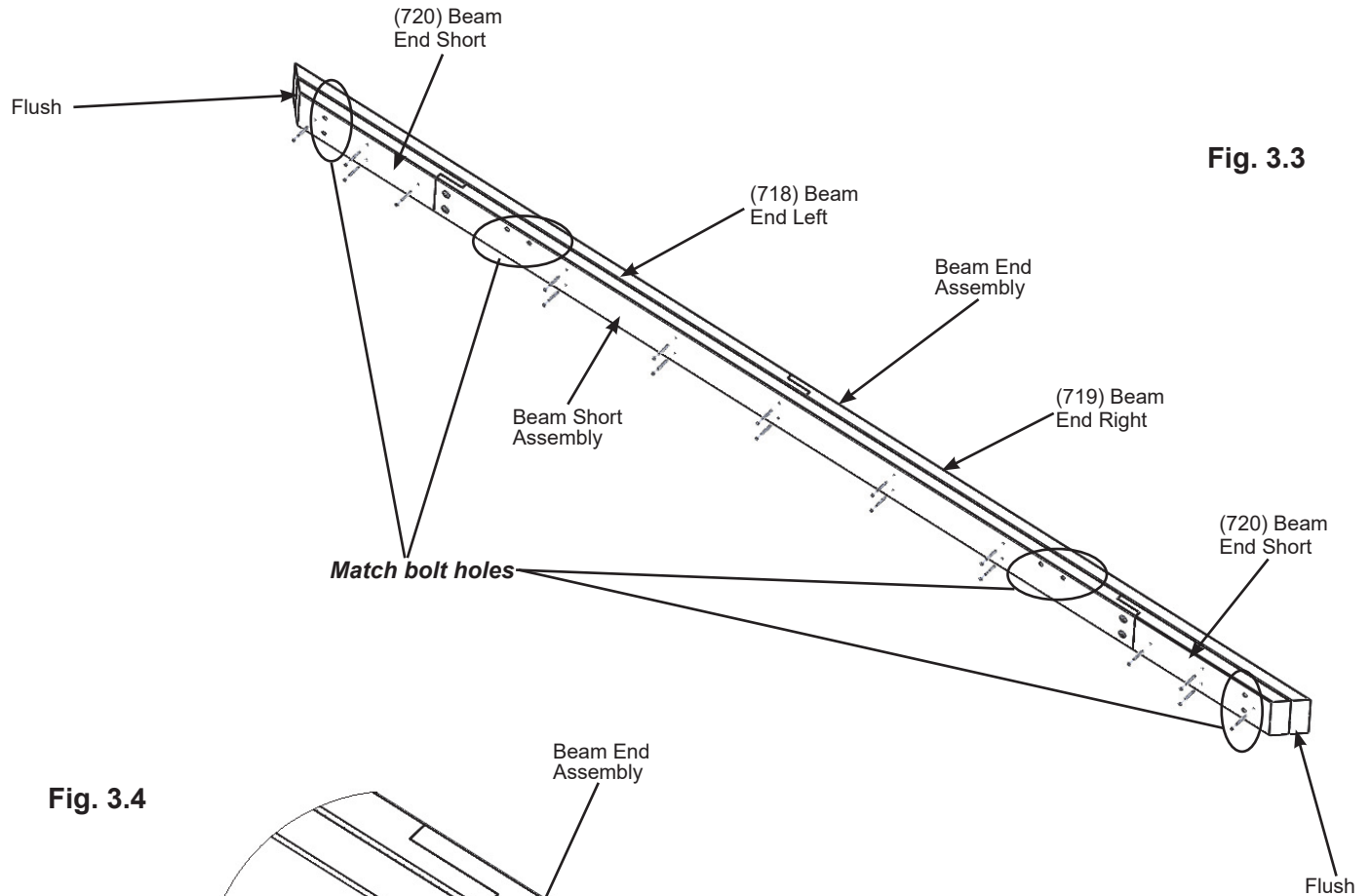
### Hardware

- 24 x 5/16 x 1-1/2" Hex Bolt  
(5/16" lock washer, 1/4-5/16" large washer, 5/16" t-nut)

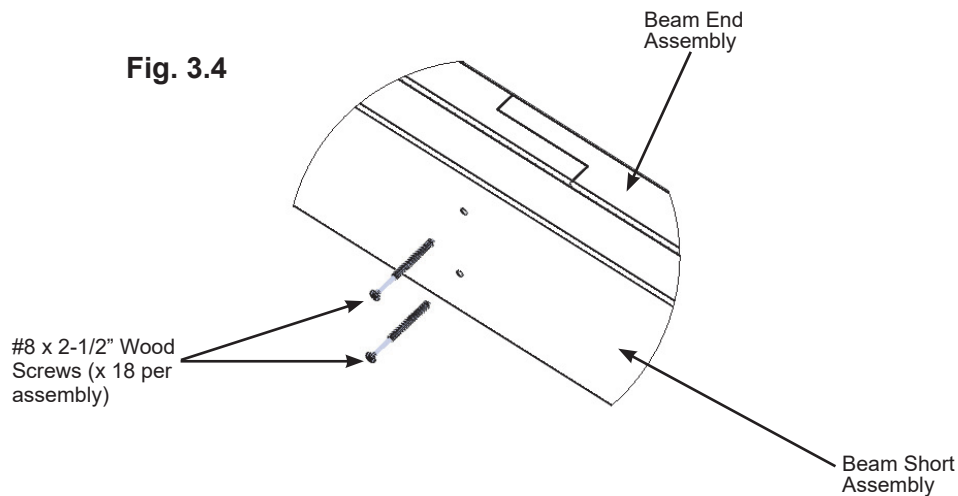
## Step 3: Beam Assembly Part 2

**D:** Place one Beam Short Assembly on one Beam End Assembly so the ends are flush. Match the bolt holes in each (720) Beam End Short with the bolt holes in (718) Beam End Left and (719) Beam End Right. Attach with 18 #8 x 2-1/2" Wood Screws. (fig. 3.3 and 3.4)

**E:** Repeat Step D three more times to make four Beam Assemblies.



**Fig. 3.3**



**Fig. 3.4**

### **Hardware**

**72 x #8 x 2-1/2" Wood Screw**

# Step 4: Frame Assembly and Anchoring Part 1



**A:** Move your Post Assemblies to the final location. Make sure the ground is flat and level before continuing assembly.

**B:** With one person at each Post stand two complete Post Assemblies. A third person places one Beam Assembly against the outside of each Post, flush to the tops and outside corners. Notice bolt hole orientation on the Beam Assembly. A fourth person attaches Beam to Post with one 3/8 x 9-1/2" Hex Bolt (with two 3/8" large washers and one 3/8" lock nut) per Post. The distance from the outside of one Post to the outside of the second Post should be 11' 0". (fig. 4.1, 4.2 and 4.3)

**C:** Continue until all four Beam Assemblies are attached and the corners are tight together. (fig. 4.1 and 4.2) See fig. 4.3 for accurate positioning of Posts.

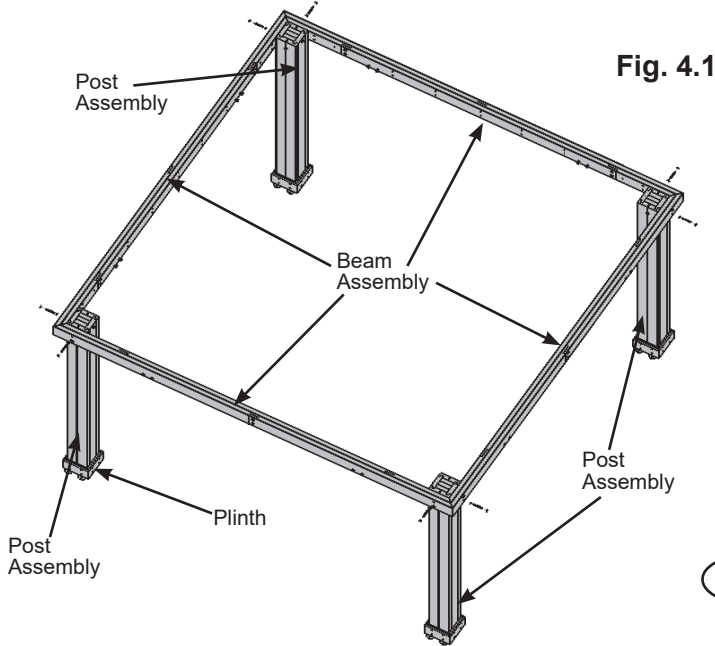


Fig. 4.1

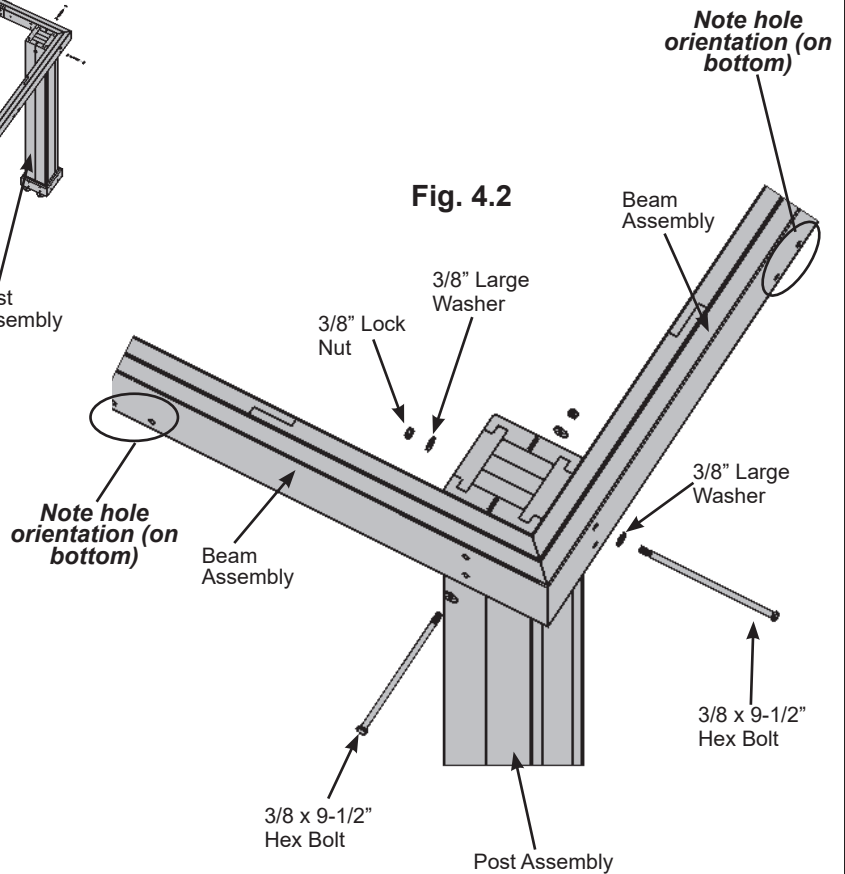


Fig. 4.2

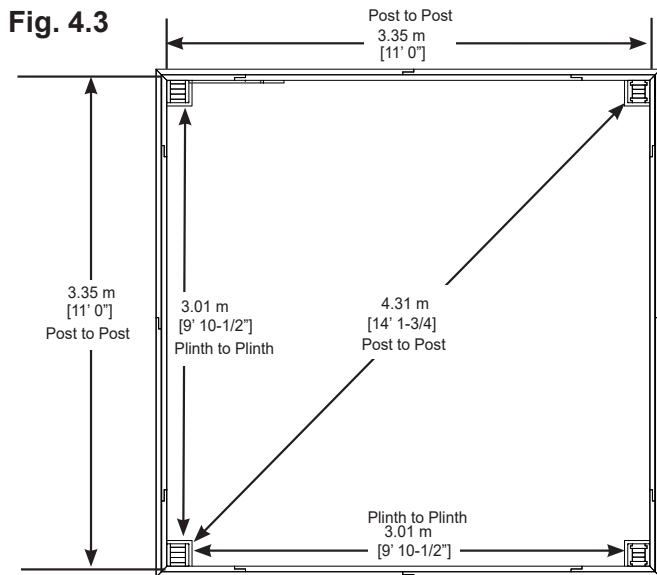


Fig. 4.3

## Hardware

8 x 3/8 x 9-1/2" Hex Bolt (3/8" large washer x 2, 3/8" lock nut)

## Step 4: Frame Assembly and Anchoring Part 2

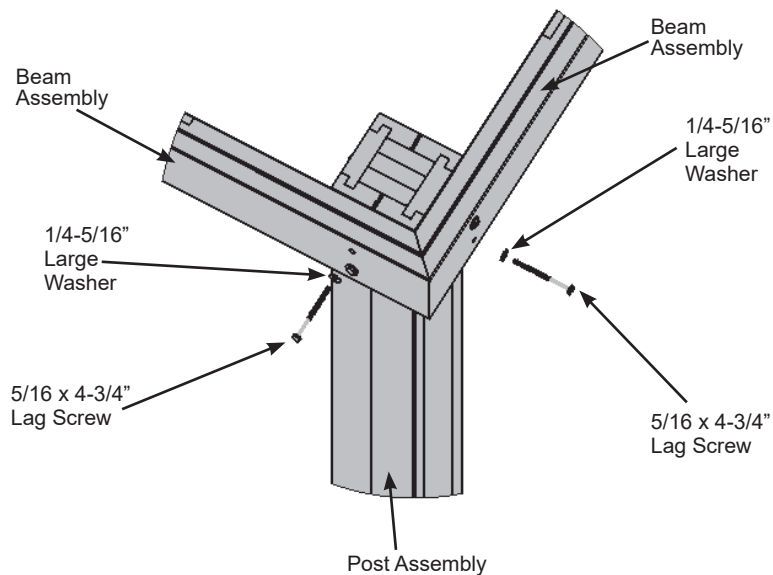


**D:** Make sure each corner is square and level then attach Beam Assemblies to Post Assemblies with two 5/16 x 4-3/4" Lag Screws (with 1/4-5/16" large washer) per corner. (fig. 4.4)

**E:** Depending on what you are placing the Pergola Room on will determine how you anchor it to that surface. Please refer to pages 6 and 7 for installation examples.

***Any hardware or extra materials for mounting will have to be purchased in advance.***

**Fig. 4.4**



### Hardware

8 x 5/16 x 4-3/4" Lag Screw (1/4-5/16" large washer)



# Step 5: Attach Gussets and Roof Brackets



**Note:** The bevelled ends on each gusset should always face away from the wood it is attaching to.

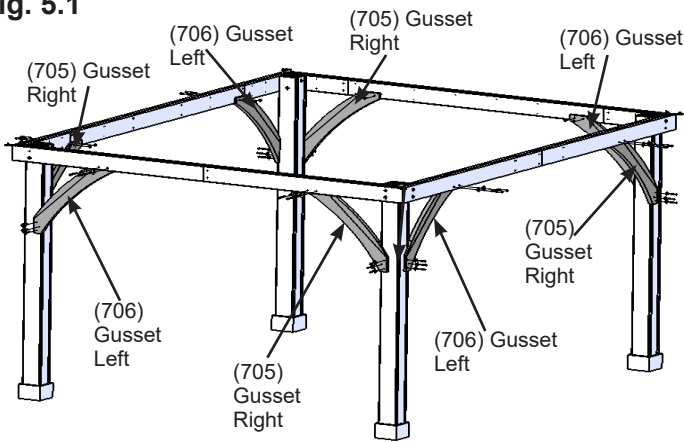
**A:** Make sure the assembly is still square and level then facing one Beam Assembly place one (705) Gusset Right on the right hand side so the top fits tight to the Beam Assembly and the bottom fits tight to the Post Assembly. Attach gusset to Beam Assembly with two 5/16 x 3-3/4" Hex Bolts (with 5/16" lock washer, 1/4-5/16" large washer and 5/16" t-nut) and to Post Assembly with three 1/4 x 1-15/16" Hex Lags (with 1/4-5/16" large washer). (fig. 5.1, 5.2 and 5.3)

**B:** Repeat Step A on the left hand side with one (706) Gusset Left. (fig. 5.1, 5.2 and 5.3)

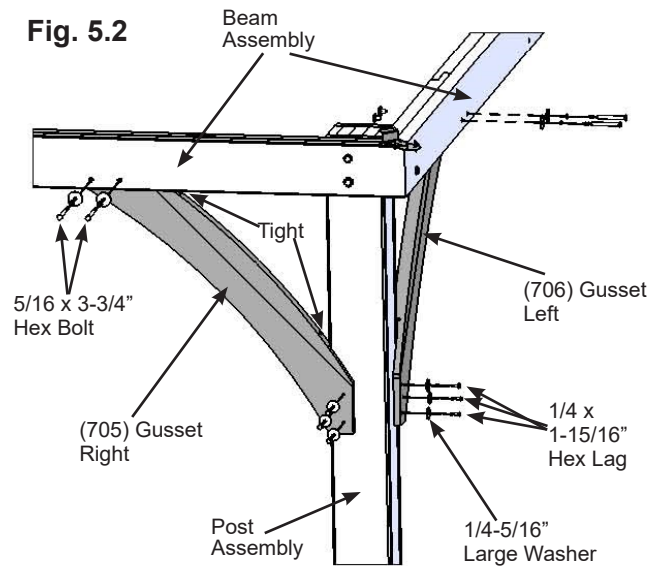
**C:** Repeat Steps A and B for each Beam Assembly/Post Assembly. (fig. 5.1, 5.2 and 5.3)

**D:** At each corner, tight to the outside edges of the joining Beam Assemblies attach one Roof to Post Bracket with two #10 x 1-1/4" Pan Screws. (fig. 5.3 and 5.4)

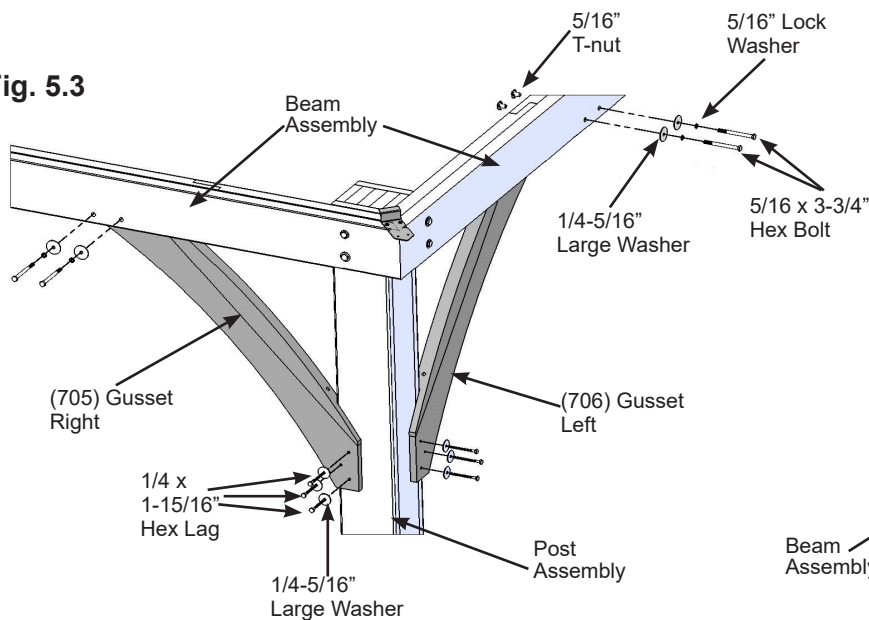
**Fig. 5.1**



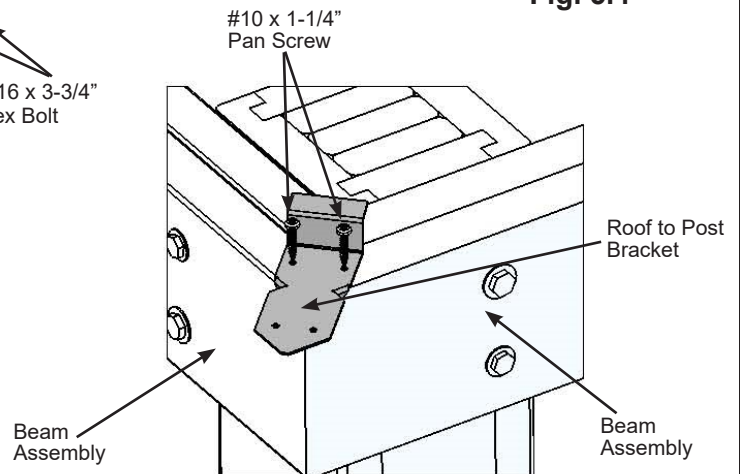
**Fig. 5.2**



**Fig. 5.3**



**Fig. 5.4**



**Wood Parts**

- 4 x (705) Gusset Right
- 4 x (706) Gusset Left

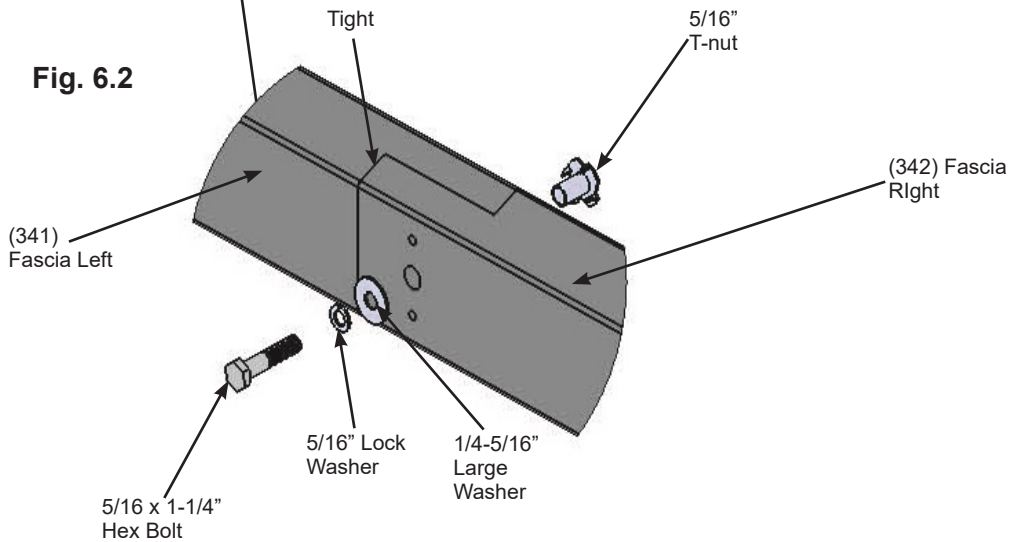
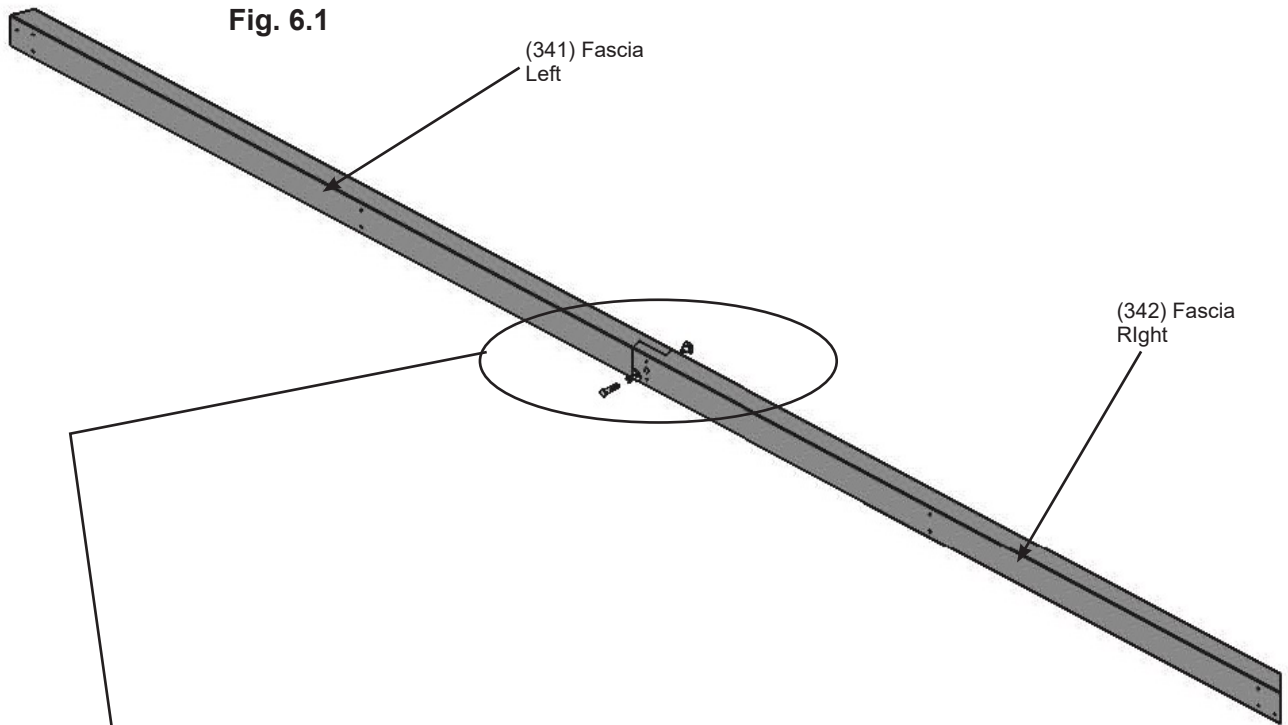
**Hardware**

- 24 x 1/4 x 1-15/16" Hex Lag (1/4-5/16" large washer)
- 16 x 5/16 x 3-3/4" Hex Bolt (5/16" lock washer, 1/4-5/16" large washer, 5/16" t-nut)
- 8 x #10 x 1-1/4" Pan Screw
- 4 x Roof to Post Bracket

## Step 6: Fascia Beam Assembly

**A:** Tightly connect one (341) Fascia Left and one (342) Fascia Right using one 5/16 x 1-1/4" Hex Bolt (with 5/16" lock washer, 1/4-5/16" large washer and 5/16" t-nut) as shown in fig. 6.1 and 6.2.

**B:** Repeat Step A three more times to make four Fascia Beam Assemblies.



### Wood Parts

4 x (341) Fascia Left  
4 x (342) Fascia Right

### Hardware

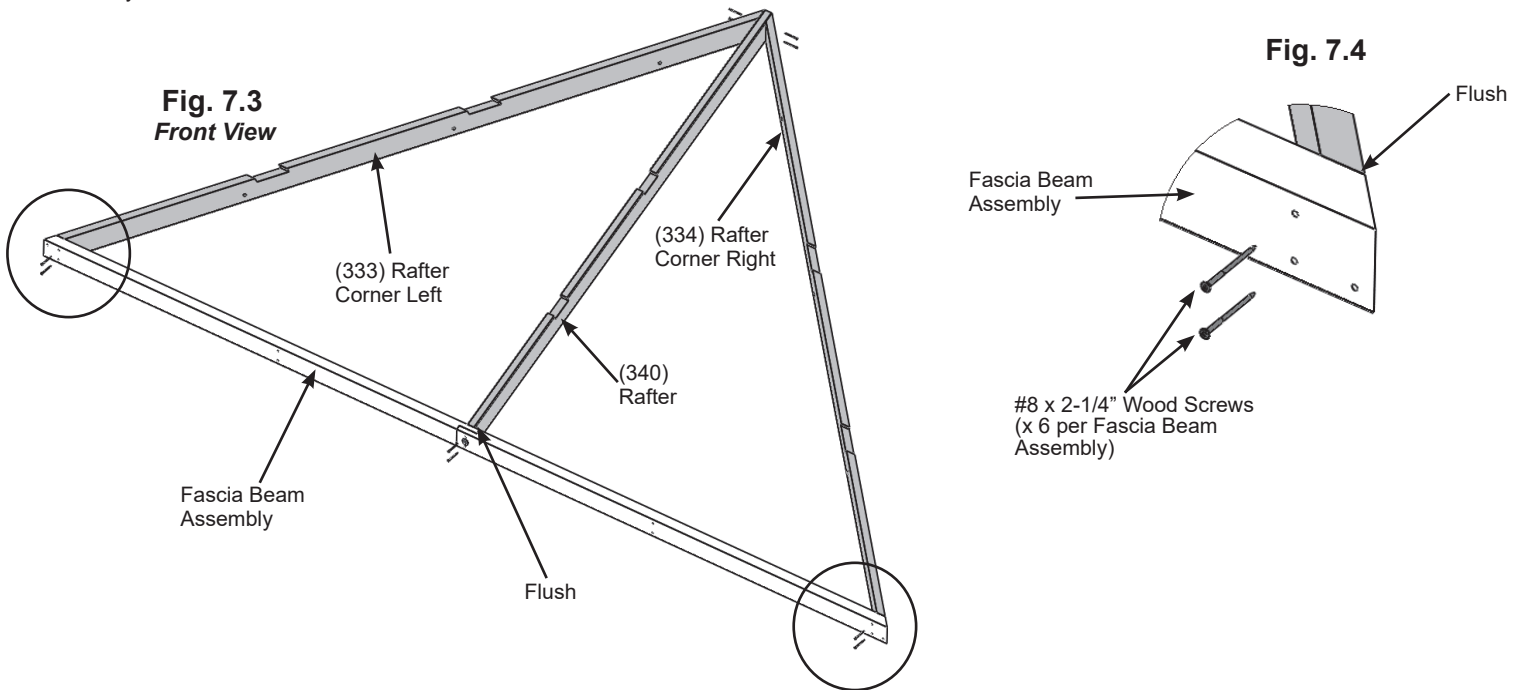
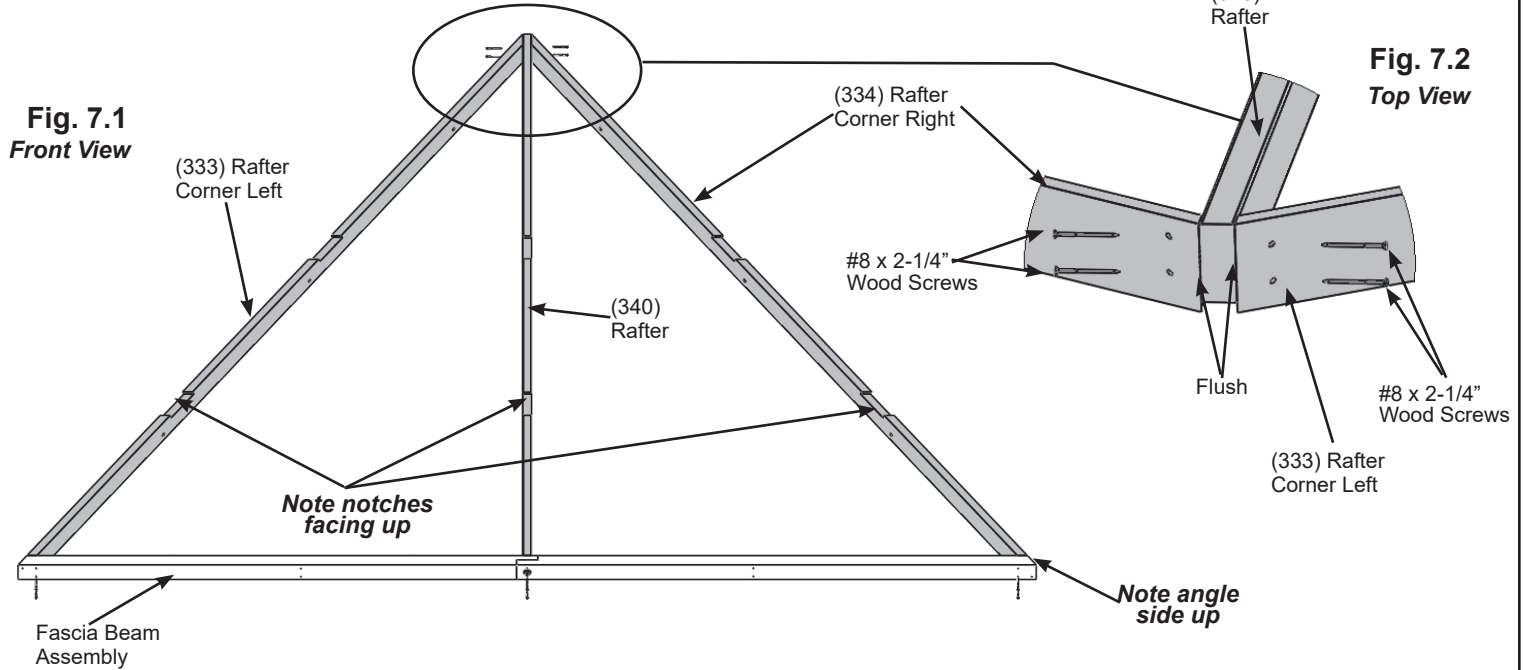
4 x 5/16 x 1-1/4" Hex Bolt  
(5/16" lock washer, 1/4-5/16" large washer, 5/16" t-nut)

# Step 7: Roof Rafter Assembly Part 1

**A:** On each side of one (340) Rafter place one (333) Rafter Corner Left and one (334) Rafter Corner Right so the tops and edges are flush then attach with two #8 x 2-1/4" Wood Screws per side. (Fig. 7.1 and 7.2)

**B:** Place Fascia Beam Assembly from Step 6 on the bottom of (333) Rafter Corner Left, (334) Rafter Corner Right and (340) Rafter so the sides are flush then attach with two #8 x 2-1/4" Wood Screws at each end and two in the middle. (fig. 7.1, 7.3 and 7.4)

**C:** Repeat Steps A and B three more times to make four Roof Rafter Assemblies.



### Wood Parts

- 4 x (340) Rafter
- 4 x (333) Rafter Corner Left
- 4 x (334) Rafter Corner Right

### Hardware

- 40 x #8 x 2-1/4" Wood Screw

# Step 7: Roof Rafter Assembly Part 2

**D:** Place one (337) Strap Short in the notches of (333) Rafter Corner Left, (334) Rafter Corner Right and (340) Rafter so the ends do not overhang the outside edges of the outside boards then attach with six #8 x 1-1/2" Wood Screws. (Fig. 7.5)

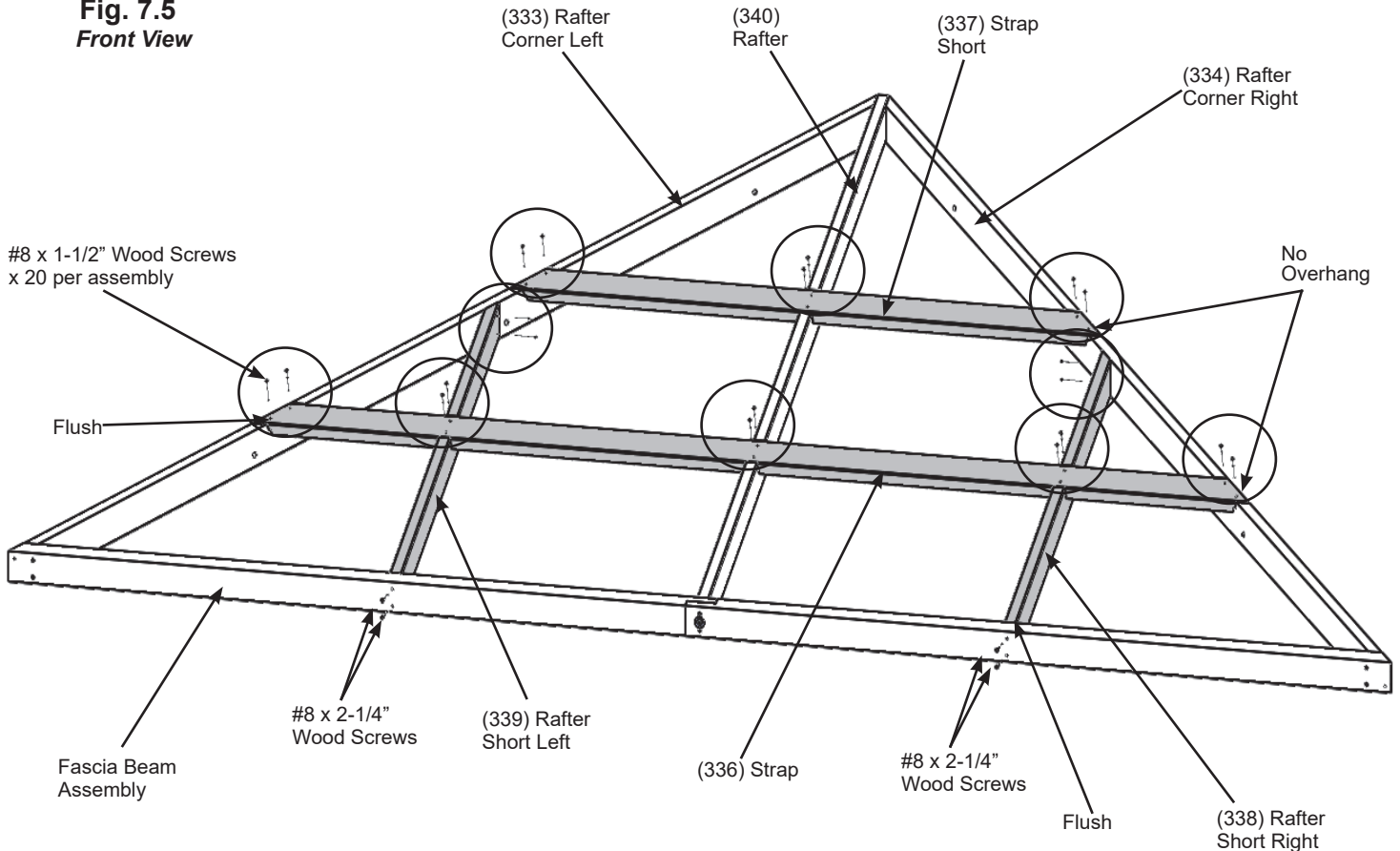
**E:** Place one (336) Strap in the notches of (333) Rafter Corner Left, (334) Rafter Corner Right and (340) Rafter so the ends do not overhang the outside edges of the outside boards. Do not attach yet. (fig. 7.5)

**F:** Place one (338) Rafter Short Right and one (339) Rafter Short Left in the notches of (336) Strap and attach as shown in fig. 7.5 with four #8 x 1-1/2" Wood Screws and two #8 x 2-1/4" Wood Screws per board.

**G:** Attach (336) Strap to (333) Rafter Corner Left, (334) Rafter Corner Right and (340) Rafter with six #8 x 1-1/2" Wood Screws. (fig. 7.5)

**H:** Complete Steps D, E, F and G for all four Roof Rafter Assemblies.

**Fig. 7.5**  
**Front View**



**Wood Parts**

- 4 x (337) Strap Short
- 4 x (336) Strap
- 4 x (338) Rafter Short Right
- 4 x (339) Rafter Short Left

**Hardware**

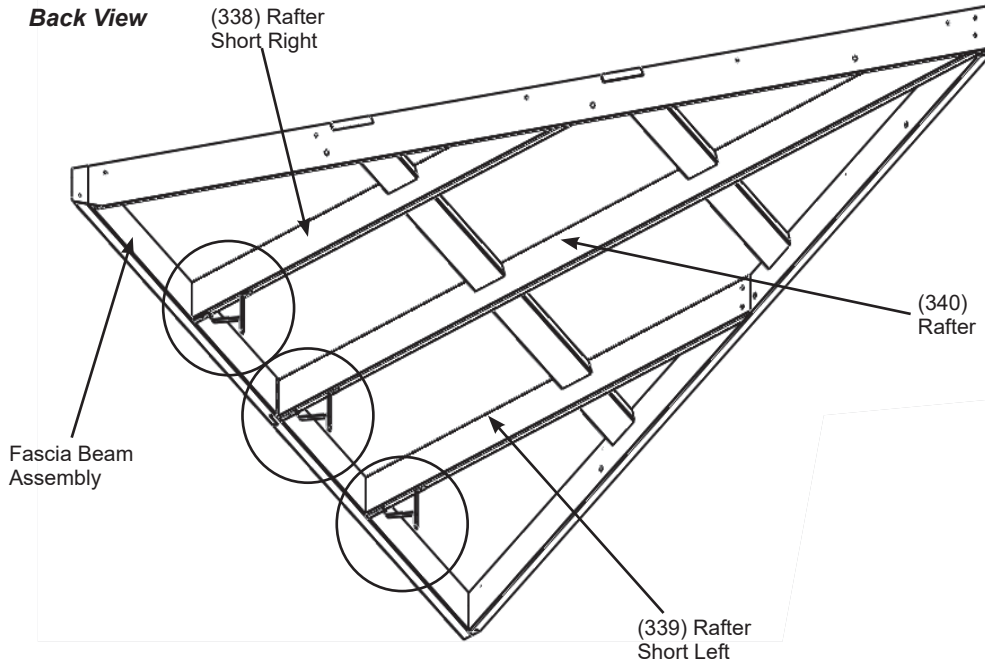
- 80 x #8 x 1-1/2" Wood Screw
- 16 x #8 x 2-1/4" Wood Screw

## Step 8: Attach Roof to Beam Brackets

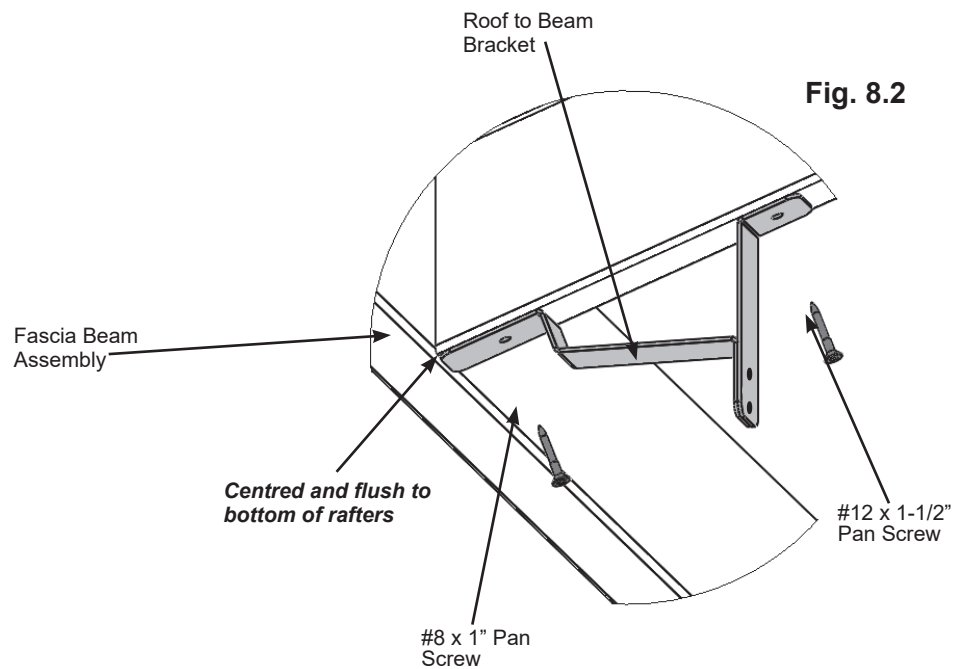
**A:** On the Back of the three Roof Rafter Assemblies, centred and flush to the bottom of (338) Rafter Short Right, (339) Rafter Short Left and (340) Rafter attach one Roof to Beam Bracket per board with one #8 x 1" Pan Screw in the bottom hole and one #12 x 1-1/2" Pan Screw in the top hole per bracket. One Roof Rafter Assembly will not have brackets. (fig. 8.1 and 8.2)

**Fig. 8.1**

**Back View**



**Fig. 8.2**



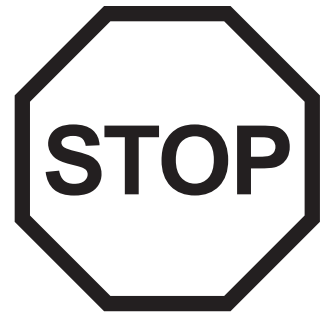
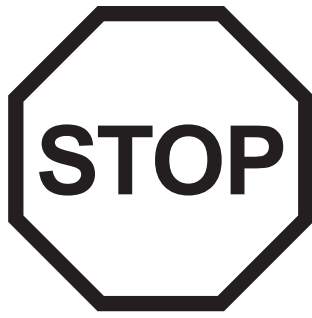
### Componets:

9 x Roof to Beam Bracket

### Hardware

9 x #8 x 1" Pan Screw

9 x #12 x 1-1/2" Pan Screw



# INSTALLING ROOFING MATERIAL

---

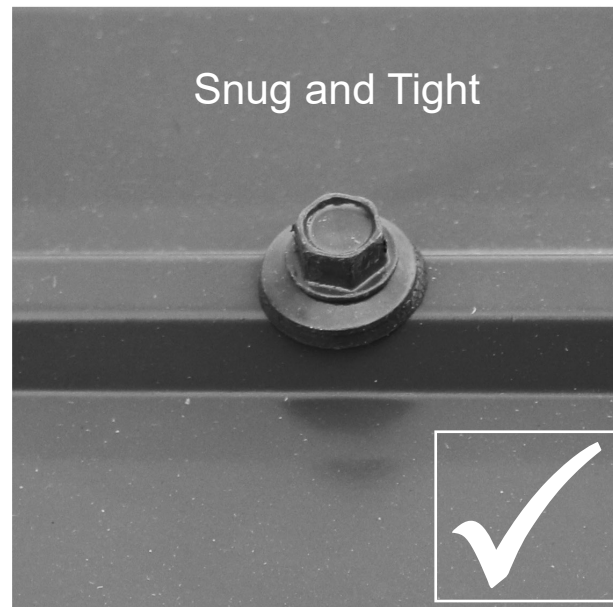
## CAUTION!

Roofing material may have sharp edges! Wear gloves!

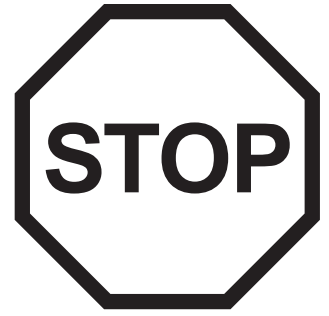
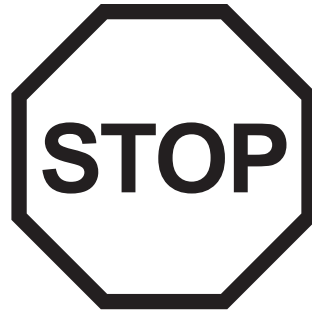
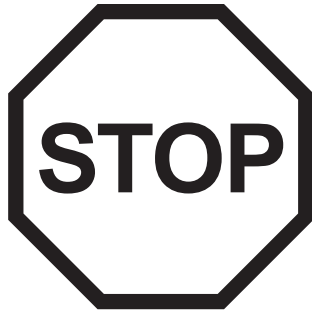
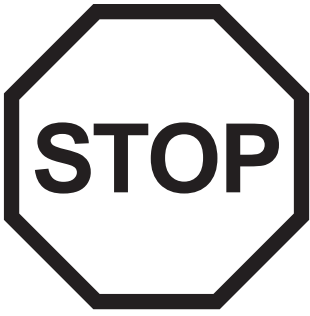
## HANDLE WITH CARE!

Place roofing material on a non-abrasive surface before assembly as it can bend, dent and scratch easily.

**WARNING – DO NOT OVER TIGHTEN ROOFING SCREWS!  
Over tightening screws will cause roofing material to crush.**



The roofing screws can easily crush the Roof Panels and Roof Edges when using a power drill. We recommend hand tightening the roofing screws so that they sit snug and tight to the roofing material.



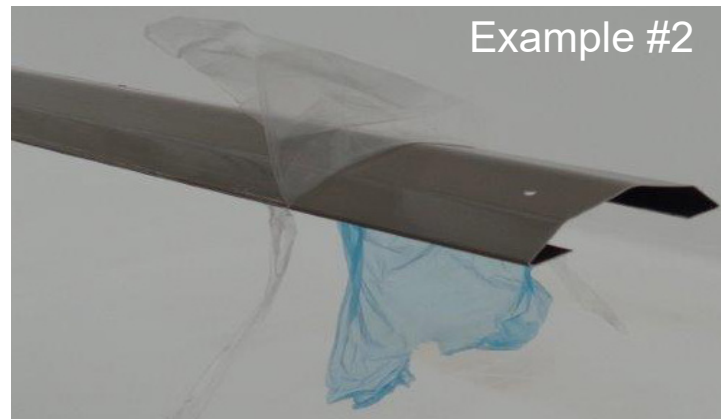
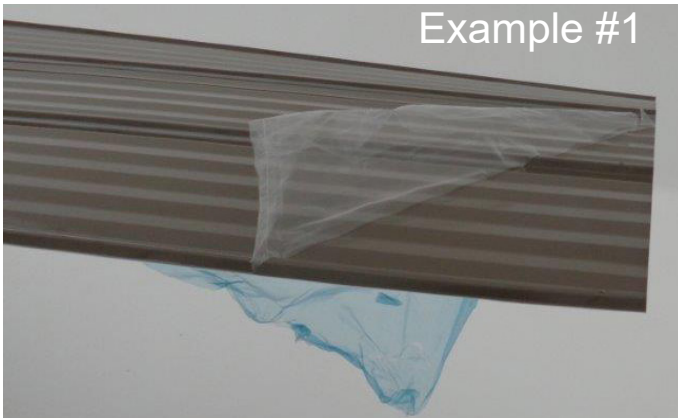
# INSTALLING ROOFING MATERIAL

---

## CAUTION!

Roofing material may have sharp edges! Wear gloves!

**BE SURE TO REMOVE ALL PLASTIC COVERING, ON BOTH SIDES OF THE ALUMINUM PANELS AND TRIM, DIRECTLY BEFORE INSTALLING EACH PIECE. *(One side is clear and the other is blue, both must be removed.)***



# Step 9: Attach Roof Panels

## Part 1

**A:** Place one Left Long Panel on the front of one Roof Rafter Assembly so it is flush to the side of (333) Rafter Corner Left and a slight overhang at the bottom of the Fascia Beam Assembly. Holes should line up with (340) Rafter. (fig. 9.1 and 9.2)

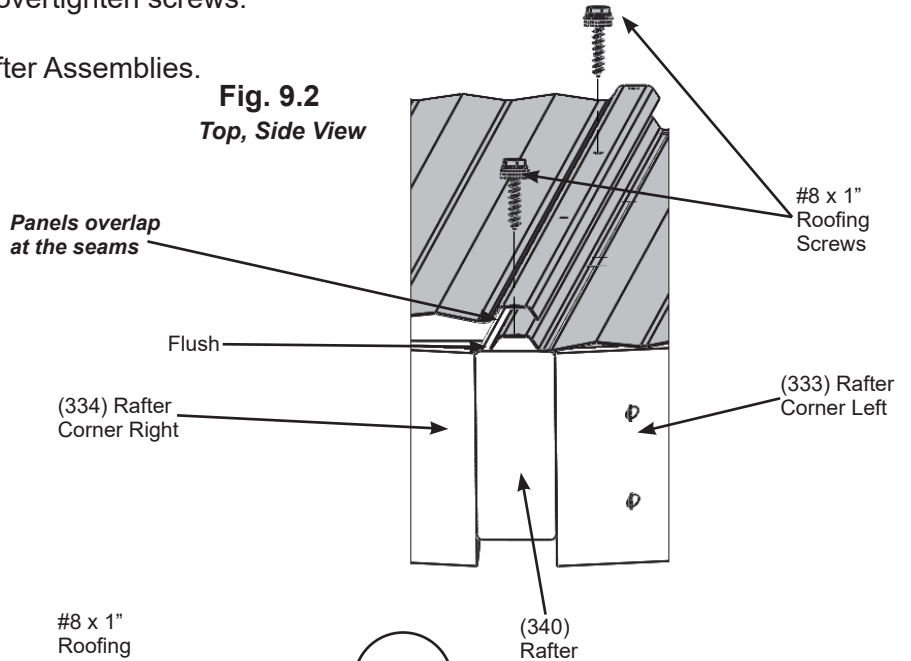
**B:** Place one Right Long Panel on Roof Rafter Assembly so it overlaps the Left Long Panel and it is flush to the side of (334) Rafter Corner Right and a slight overhang at the bottom of the Fascia Beam Assembly. (fig. 9.1 and 9.2)

**C:** Attach both Left and Right Long Panels to Roof Rafter Assembly with four #8 x 1" Roofing Screws in locations shown in fig. 9.1. Be sure not to overtighten screws.

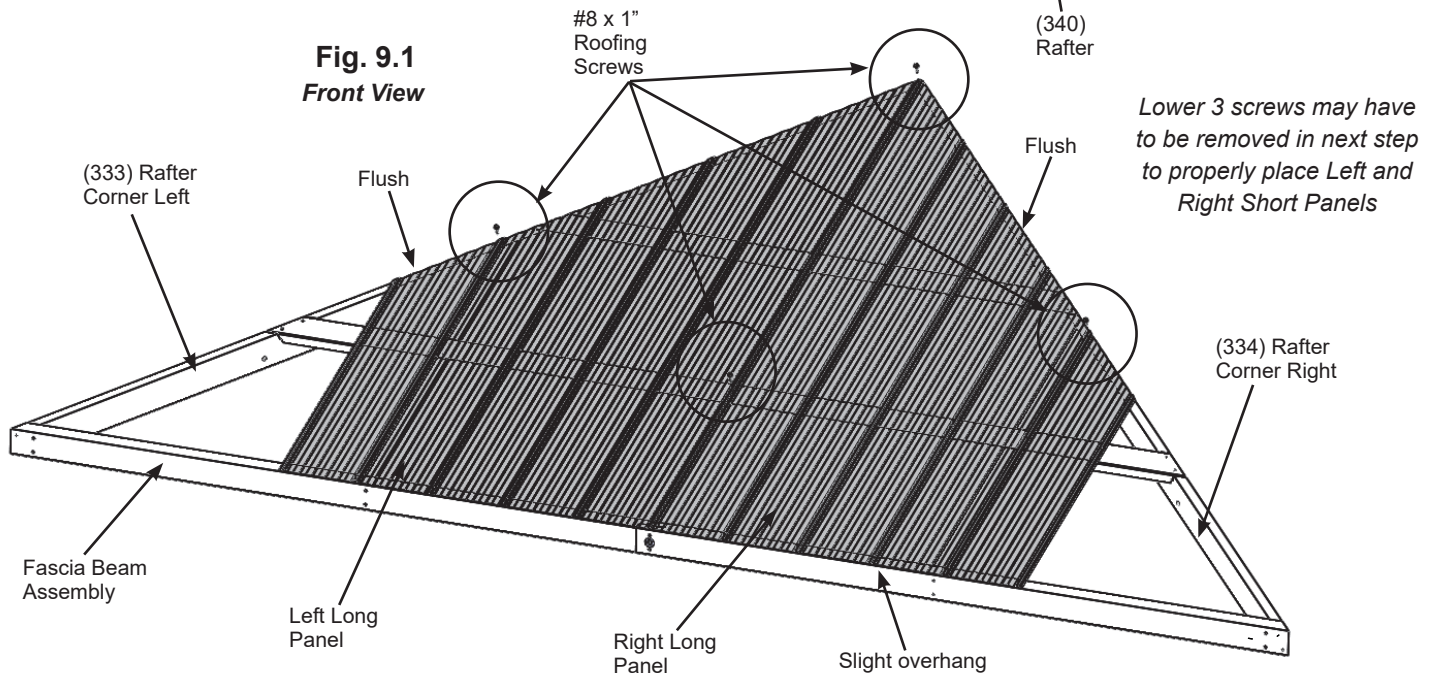
**D:** Repeat Steps A - C for all four Roof Rafter Assemblies.

**DO NOT overtighten screws, could cause damage to roofing material**

**Fig. 9.2**  
Top, Side View



**Fig. 9.1**  
Front View



**Roof Parts**

- 4 x Left Long Panel
- 4 x Right Long Panel

**Hardware**

- 16 x #8 x 1" Roofing Screw



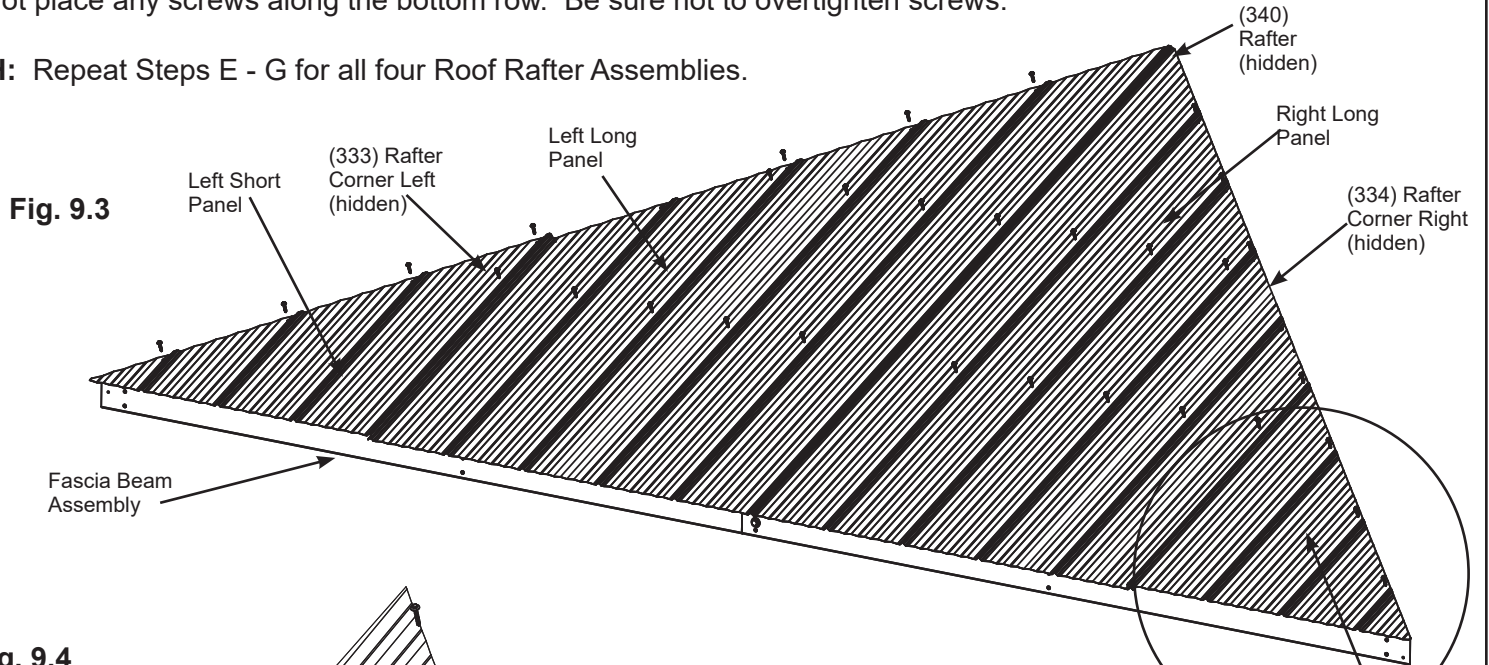
# Step 9: Attach Roof Panels Part 2

**E:** Place one Left Short Panel on Roof Rafter Assembly so it overlaps the Left Long Panel and it is flush to the sides of (333) Rafter Corner Left and a slight overhang at the bottom of the Fascia Beam Assembly. There should be no overhanging at the corners. (fig. 9.3 and 9.4)

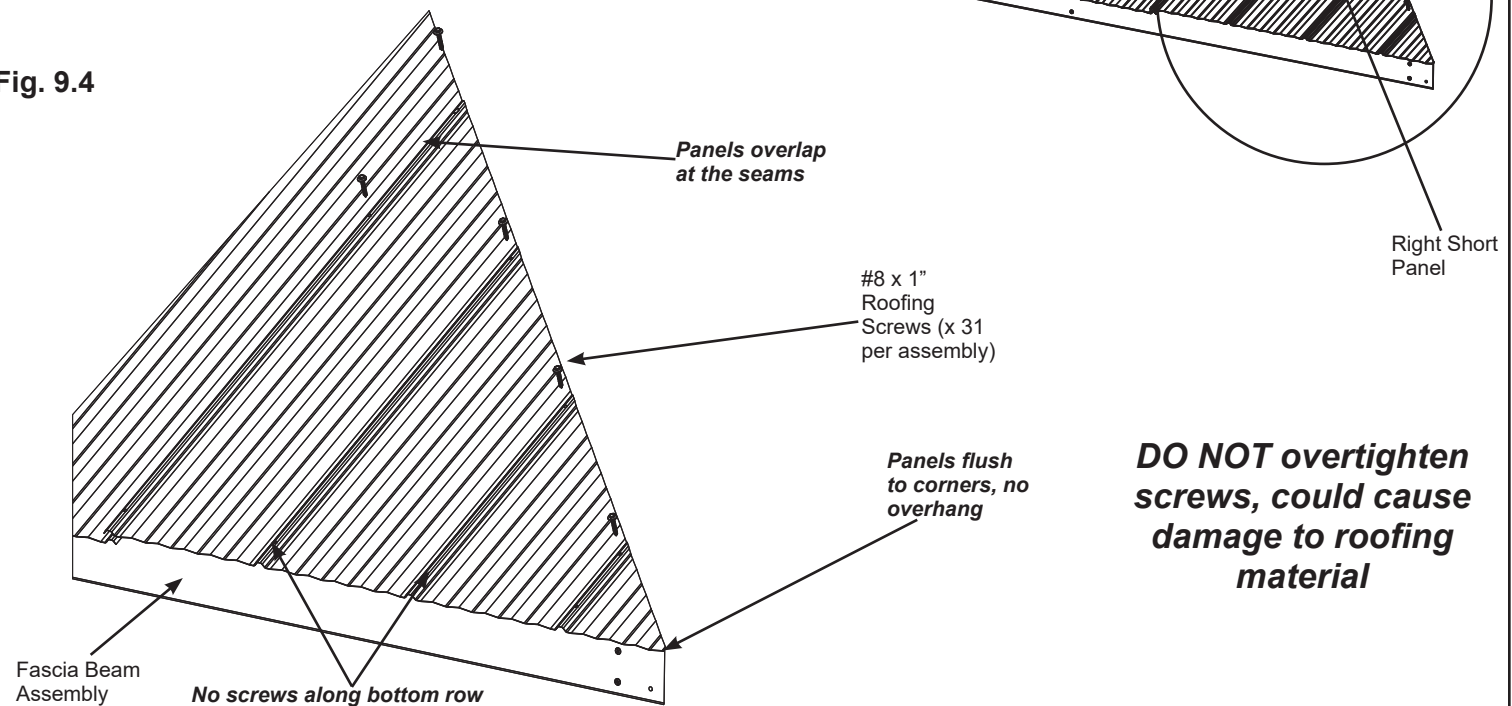
**F:** Place one Right Short Panel on Roof Rafter Assembly so it overlaps the Right Long Panel and it is flush to the side of (334) Rafter Corner Right and a slight overhang at the bottom of the Fascia Beam Assembly. There should be no overhanging at the corners. (fig. 9.3 and 9.4)

**G:** Attach all panels to Roof Rafter Assembly with 31 #8 x 1" Roofing Screws in locations shown in fig. 9.3. Do not place any screws along the bottom row. Be sure not to overtighten screws.

**H:** Repeat Steps E - G for all four Roof Rafter Assemblies.



**Fig. 9.4**



### Roof Parts

- 4 x Left Short Panel
- 4 x Right Short Panel

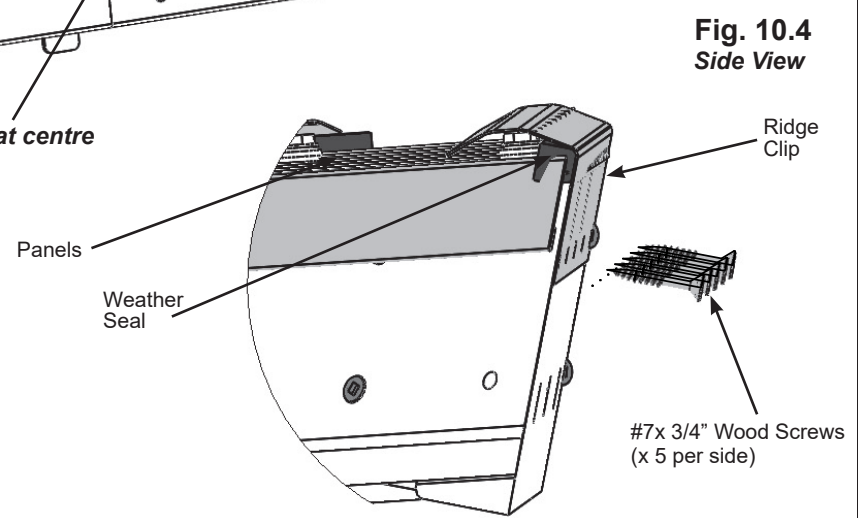
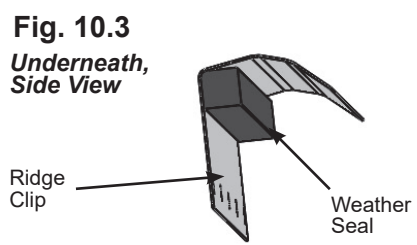
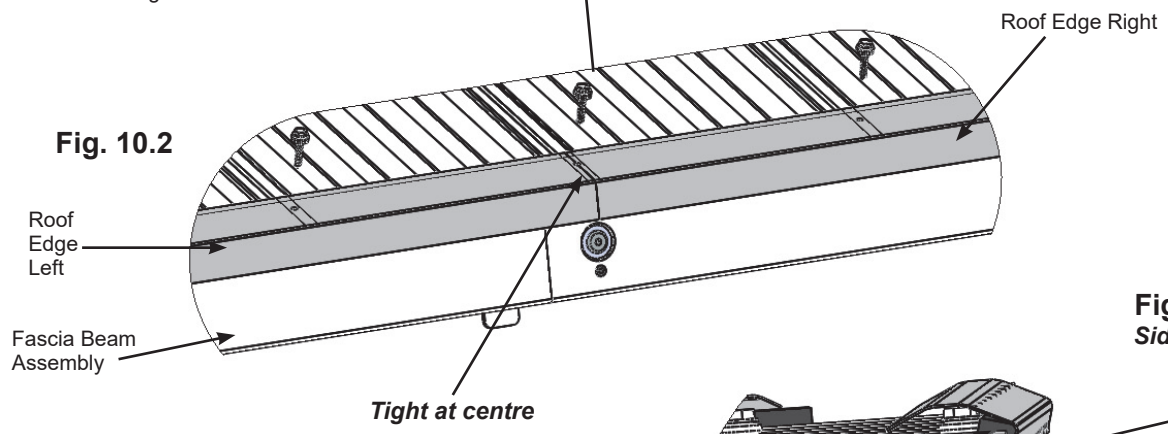
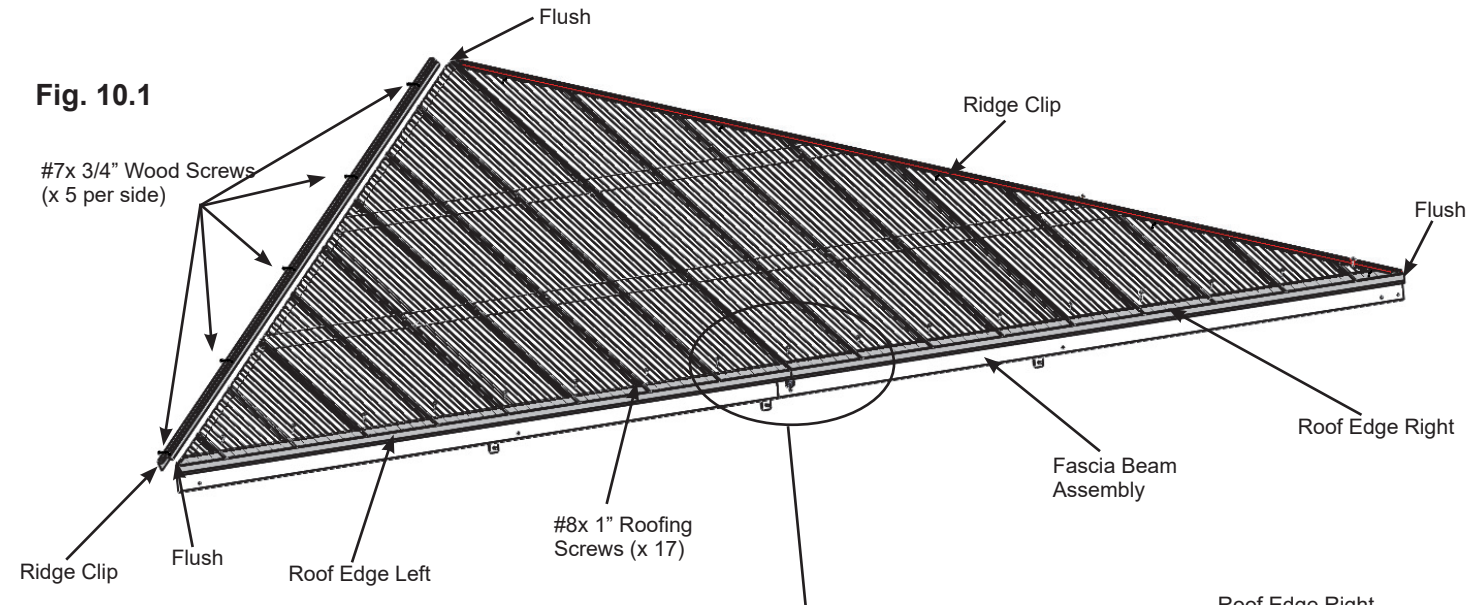
### Hardware

- 124 x #8 x 1" Roofing Screw

# Step 10: Attach Ridge Clips and Roof Edges

**A:** Place one Roof Edge Left and one Roof Edge Right on the bottom of each Roof Rafter Assembly so the ends are flush with the outside ends of the Fascia Beam Assembly and meet tight in the centre. Attach both Roof Edges with 17 #8 x 1" Roofing Screws per Roof Rafter assembly. (fig. 10.1 and 10.2)

**B:** Place one Weather Seal on the inside of each Ridge Clip then place one Ridge Clip on each side of each Roof Rafter Assembly so they cover the panels and attach with five #7 x 3/4" Wood Screws per Ridge Clip. (fig. 10.1, 10.3 and 10.4)



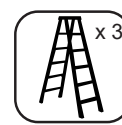
**Components:**

- 4 x Roof Edge Left
- 4 x Roof Edge Right
- 8 x Ridge Clip
- 8 x Weather Seal

**Hardware**

- 68 x #8 x 1" Roofing Screw
- 40 x #7 x 3/4" Wood Screw

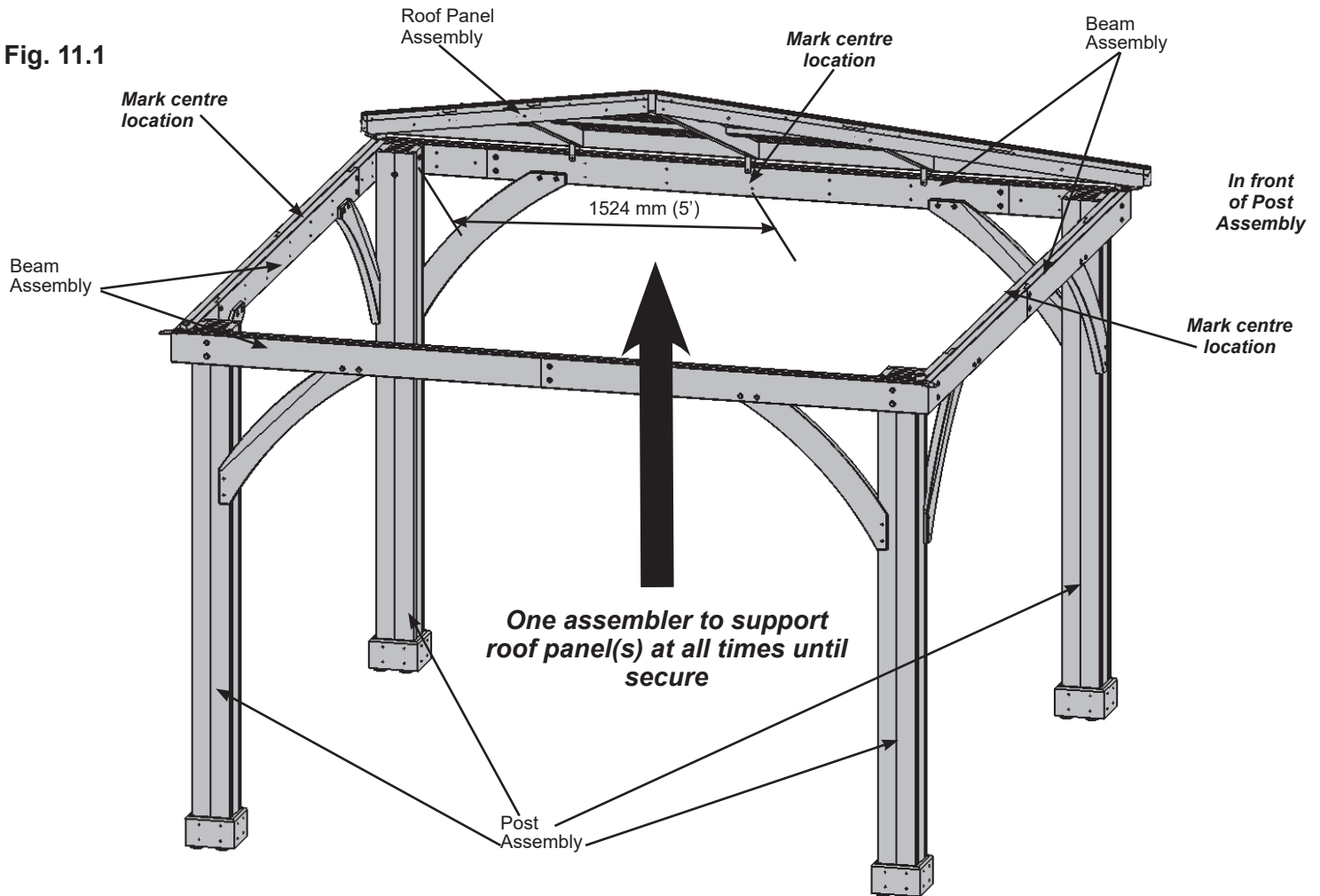
# Step 11: Attach Roof Panels to Frame Part 1



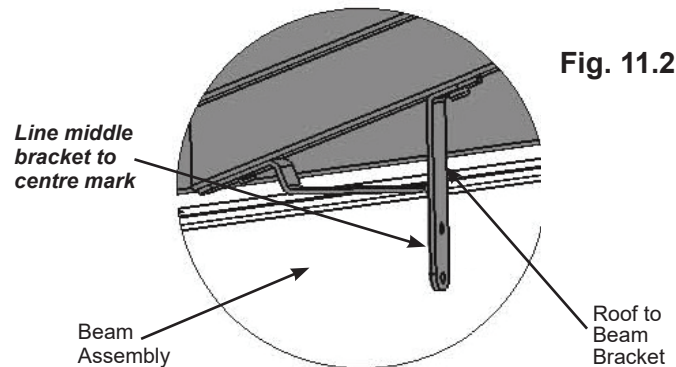
**A:** From inside of Post Assemblies measure 1524 mm (5') to mark the centre of each Beam Assembly. (fig. 11.1)

**B:** With all four assemblers place one Roof Panel Assembly with Roof to Beam Brackets just in front of the Post Assemblies then raise it up so the middle Roof to Beam Bracket is lined up with the centre mark. (fig. 11.1 and 11.2)

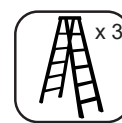
**Fig. 11.1**



**Fig. 11.2**

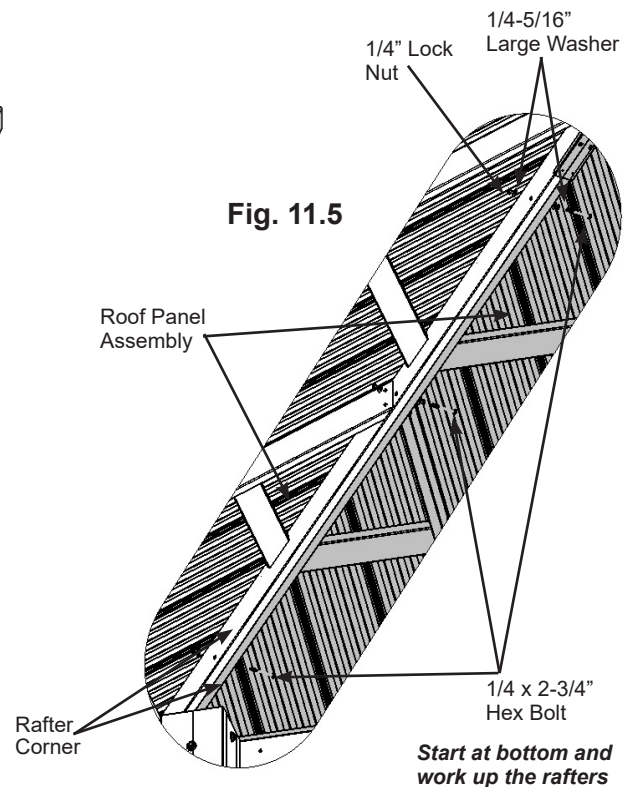
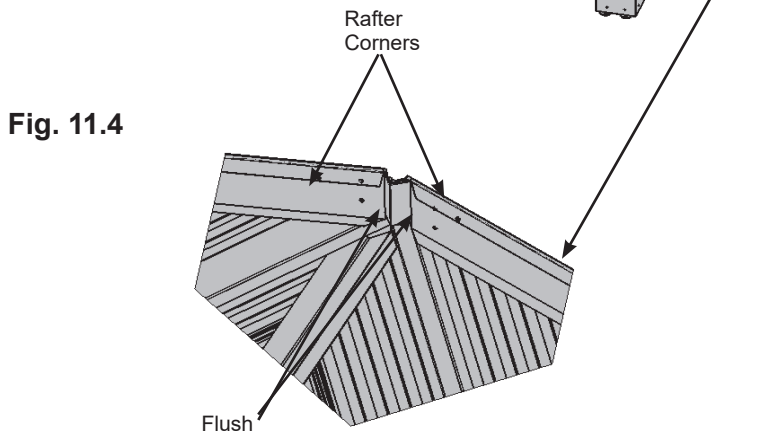
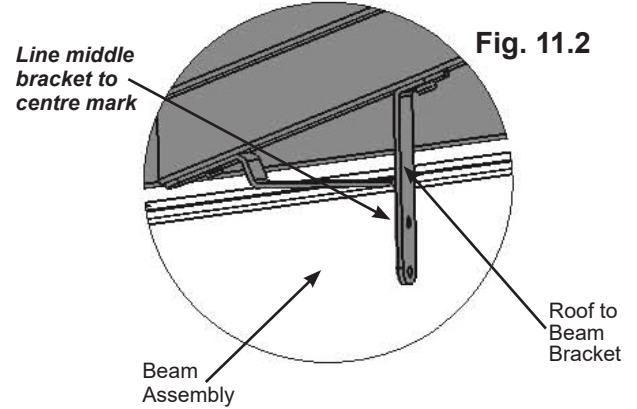
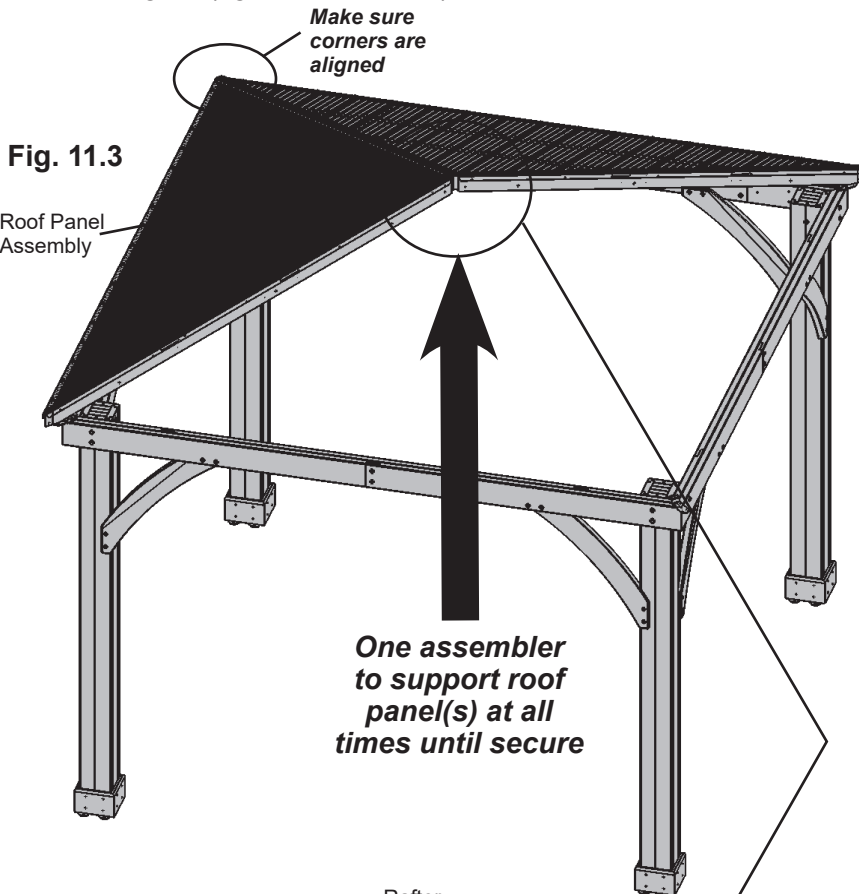


# Step 11: Attach Roof Panels to Frame Part 2



**C:** Lift a second Roof Panel Assembly with Roof to Beam Brackets over Beam Assembly taking care not to drag the panel on the beams. Make sure the middle Roof to Beam Bracket lines up to the centre mark and the Rafter Corners are flush with each other. **One person must remain on the centre ladder to hold both panels in place until three panels are up and secure.** (fig. 11.2, 11.3 and 11.4)

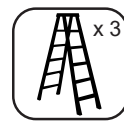
**D:** Starting at the bottom and working up connect Roof Panel Assemblies through the Rafter Corners with three 1/4 x 2-3/4" Hex Bolts (with two 1/4-5/16" large washers and one 1/4" lock nut). To align bolt holes helper in the centre may have to push up the centre of the panels and others make sure corners are aligned. Make sure all bolts are tight. (fig. 11.2 and 11.5)



## Hardware

3 x 1/4 x 2-3/4" Hex Bolt  
(1/4-5/16" large washer x 2, 1/4" lock nut)

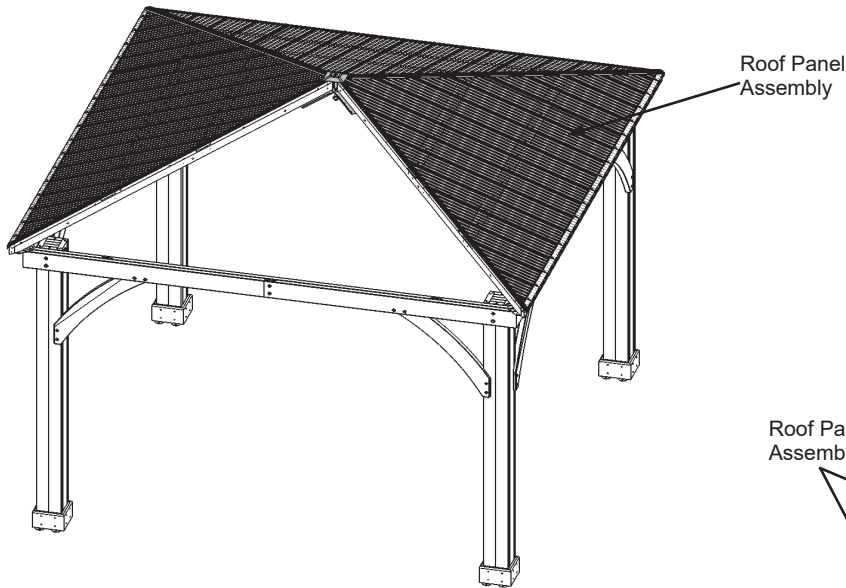
# Step 11: Attach Roof Panels to Frame Part 3



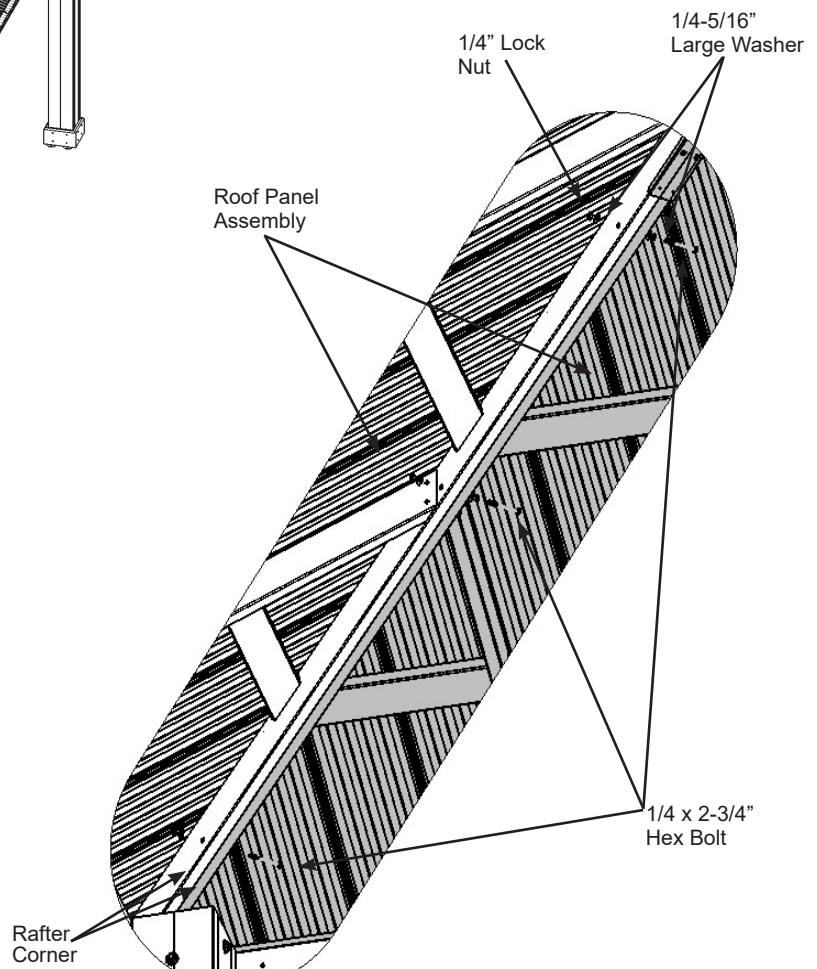
**E:** Lift third Roof Panel Assembly with Roof to Beam Brackets over Beam Assembly taking care not to drag the panel on the beams then set in place beside the second panel. Make sure the middle Roof to Beam Bracket lines up to the centre mark. (fig. 11.6)

**F:** Starting at the bottom and working up connect Roof Panel Assemblies through the Rafter Corners with three 1/4 x 2-3/4" Hex Bolts (with two 1/4-5/16" large washers and one 1/4" lock nut). To align bolt holes helper on the centre ladder may have to push up in the centre of the panels and others make sure corners are aligned. Make sure all bolts are tight. (fig. 11.7)

**Fig. 11.6**



**Fig. 11.7**



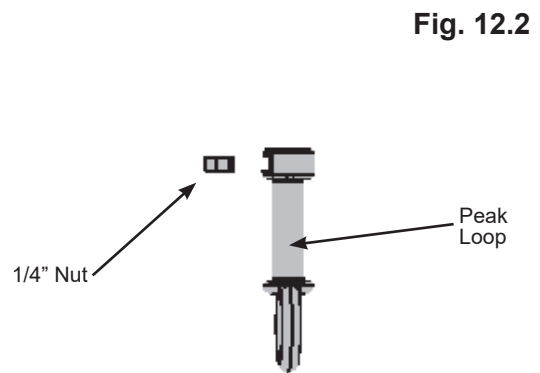
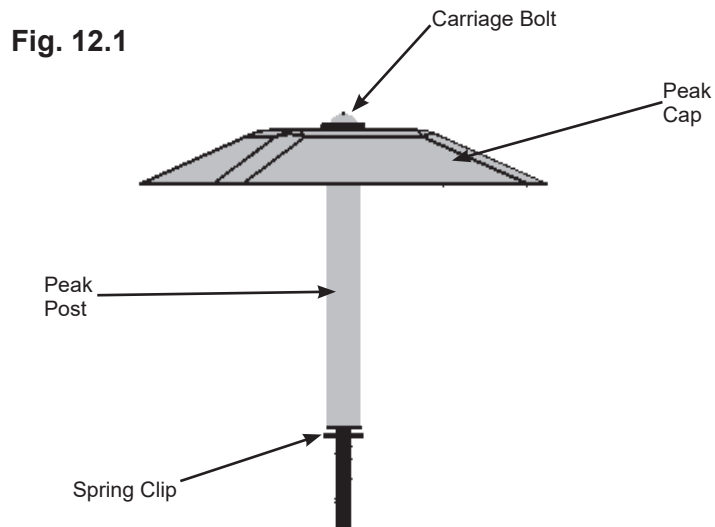
### Hardware

3 x 1/4 x 2-3/4" Hex Bolt  
(1/4-5/16" large washer x 2, 1/4" lock nut)

## Step 12: Roof Peak Assembly

**A:** Insert Carriage Bolt through the top of Peak Cap, into Peak Post then Spring Clip. The Spring Clip holds the assembly together. (fig. 12.1)

**B:** Insert 1/4" Nut into Peak Loop. Be careful nut is loose and will fall out until attached to Peak Cap Assembly. (fig. 12.2)



### Componets:

1 x Roof Peak Set	1 x Peak Cap
1 x Carriage Bolt	1 x Peak Post
1 x Peak Loop	
1 x Spring Clip	
1 x 1/4" Nut	

# Step 13: Attach Roof Peak to Roof Panels

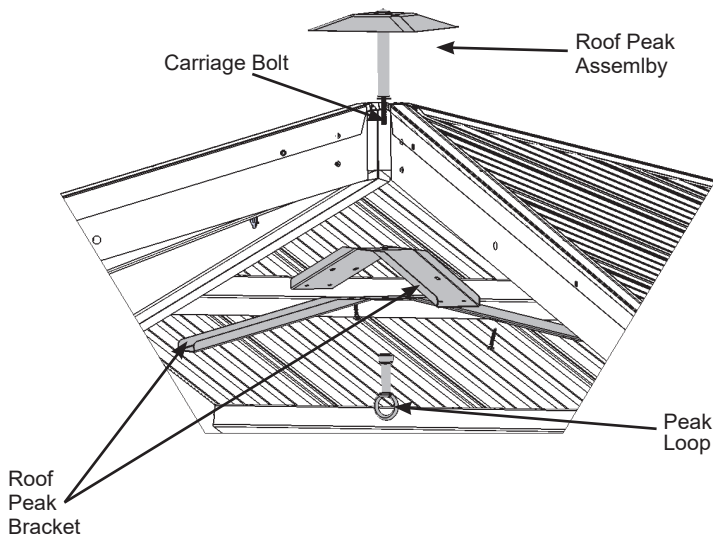


**A:** Insert Roof Peak Assembly in gap between Roof Panels. Peak Cap to be lined up with Rafter Corners. (fig. 13.1 and 13.2)

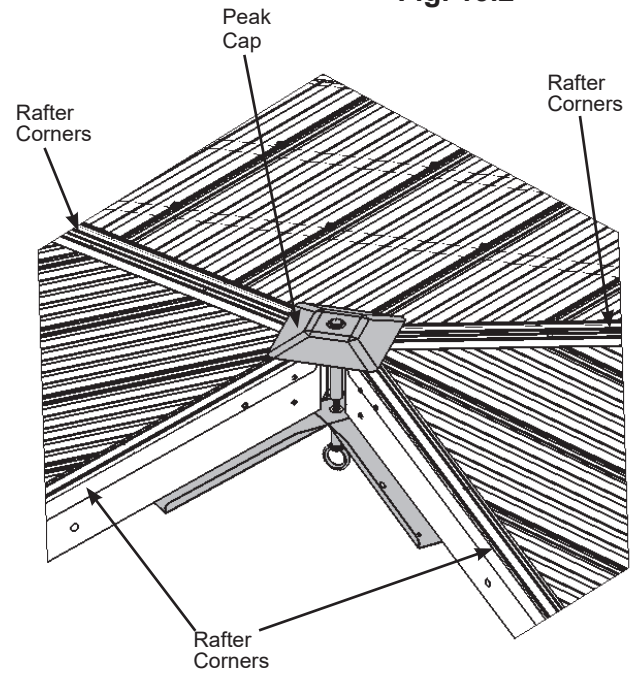
**B:** Insert both Roof Peak Brackets through Carriage Bolt and attach Peak Loop to Carriage Bolt and twist to tighten loosely.

**C:** Loosely attach both Roof Peak Brackets to the Rafter Corners in the slotted holes with two #10 x 1-1/4" Pan Screws as shown in fig. 13.3.

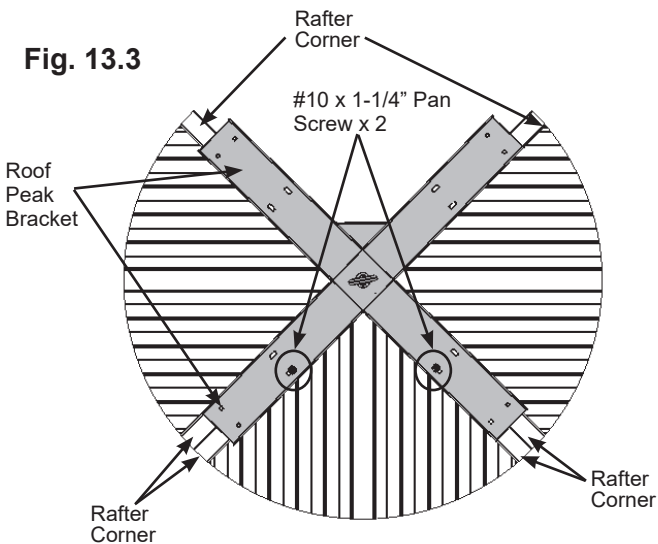
**Fig. 13.1**



**Fig. 13.2**



**Fig. 13.3**



**Components:**

2 x Roof Peak Brackets

**Hardware**

2 x #10 x 1-1/4" Pan Screw

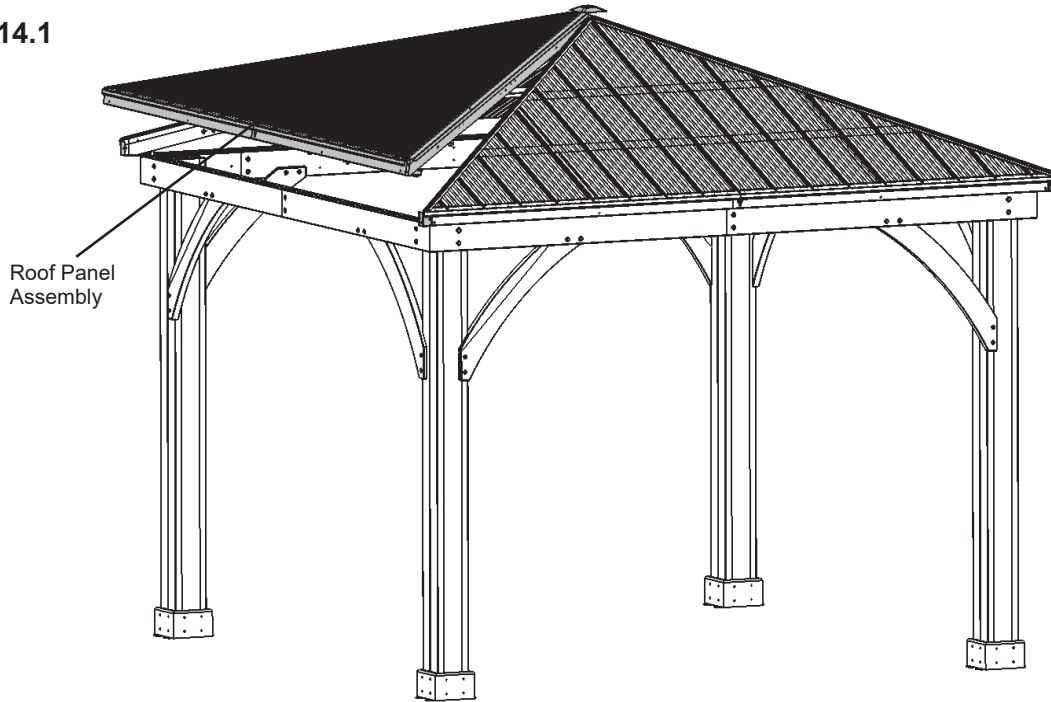
# Step 14: Attach Final Roof Panel Part 1



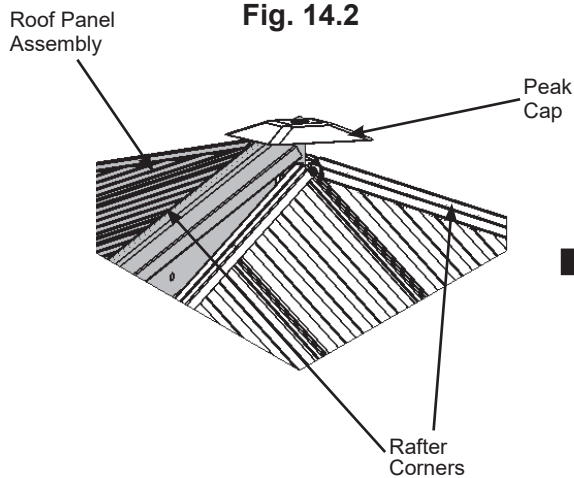
**A:** Lift last Roof Panel Assembly (without Roof to Beam Brackets) over Beam Assembly taking care not to drag the panel on the beams. Panel fits under the Peak Cap, push up on Peak Loop to lift Peak Cap. The centre of the other panels may have to be pushed up to fit fourth panel. (fig. 14.1 and 14.2)

**B:** Check again that Peak Cap is lined up with Rafter Corners. (fig. 14.3)

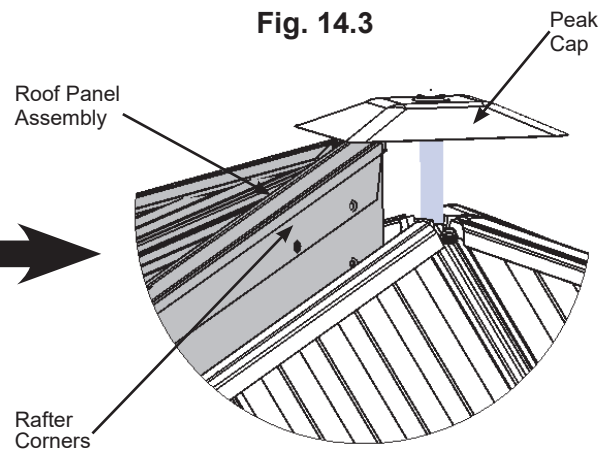
**Fig. 14.1**



**Fig. 14.2**



**Fig. 14.3**





# Step 14: Attach Final Roof Panel Part 2



Remember to push up centre to assist with alignment.

**C:** Starting at the bottom and working up loosely connect Roof Panel Assemblies through the Rafter Corners with three 1/4 x 2-3/4" Hex Bolts (with two 1/4-5/16" large washers and one 1/4" lock nut) per side. To align bolt holes helper on the centre ladder may have to push up in the centre of the panels and others make sure corners are aligned. Tighten bolts when all six have been installed. (fig. 14.4 and 14.5)

*Rafter Corners should be aligned with Roof to Post Bracket.*

Fig. 14.4

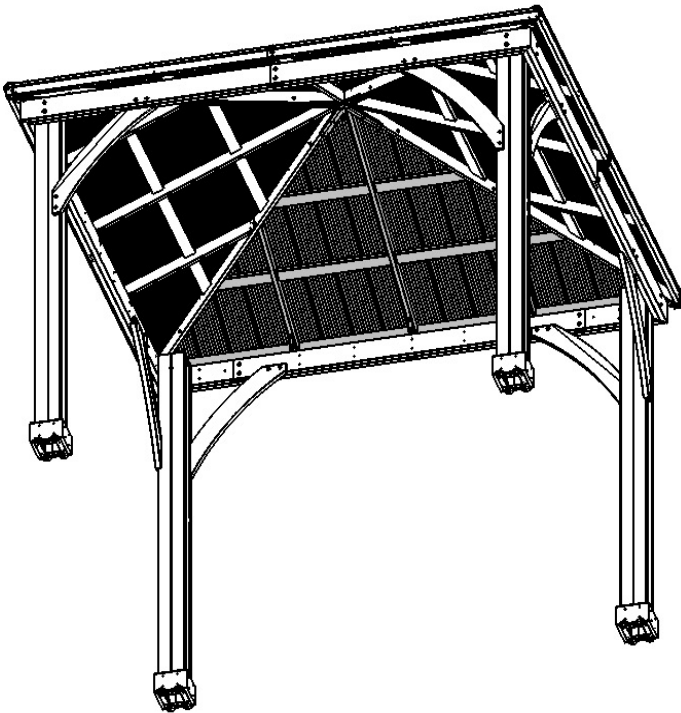
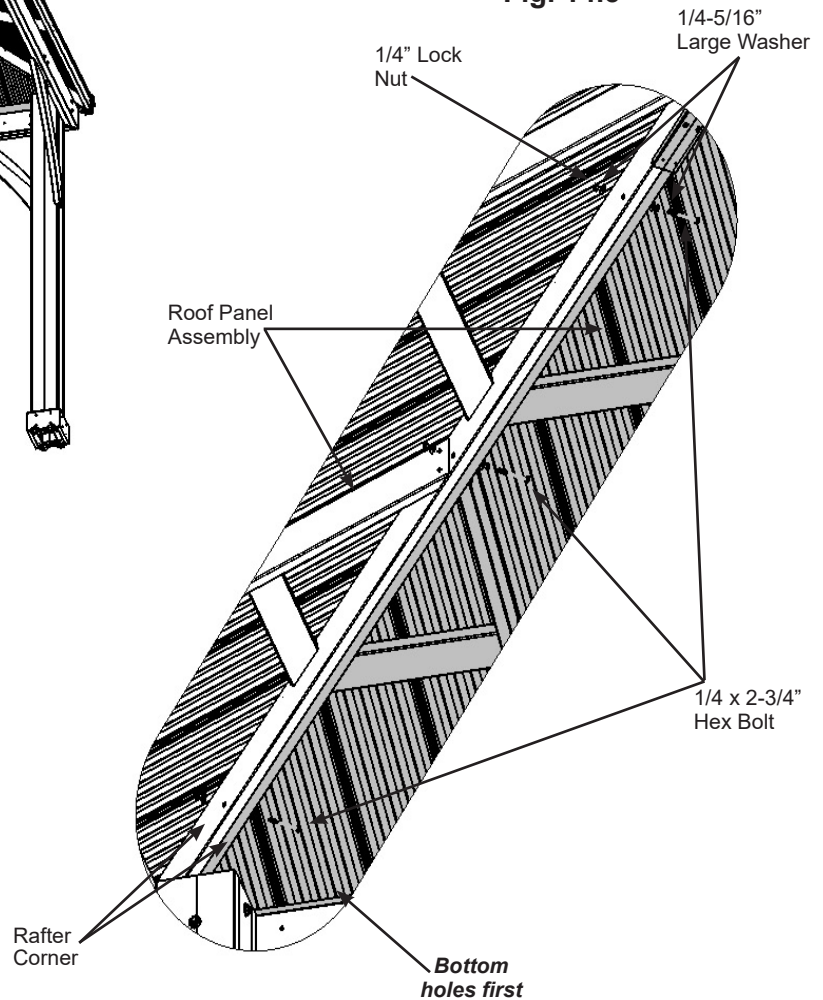


Fig. 14.5



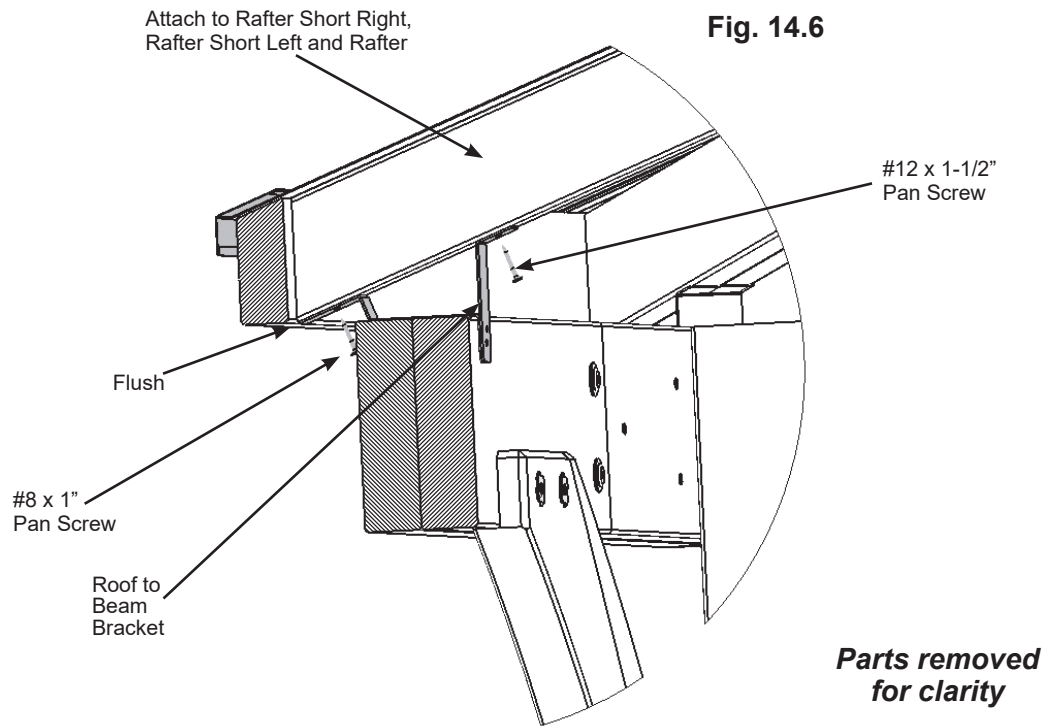
### Hardware

6 x 1/4 x 2-3/4" Hex Bolt  
(1/4-5/16" large washer x 2, 1/4" lock nut)

# Step 14: Attach Final Roof Panel Part 3



**D:** On the fourth Roof Rafter Assembly, centred and flush to the bottom of (338) Rafter Short Right, (339) Rafter Short Left and (340) Rafter attach one Roof to Beam Bracket per board with one #8 x 1" Pan Screw in the bottom hole and one #12 x 1-1/2" Pan Screw in the top hole per bracket. (fig. 14.6)



### Componets:

3 x Roof to Beam Bracket

### Hardware

3 x #8 x 1" Pan Screw

3 x #12 x 1-1/2" Pan Screw

# Step 15: Secure Roof Corners

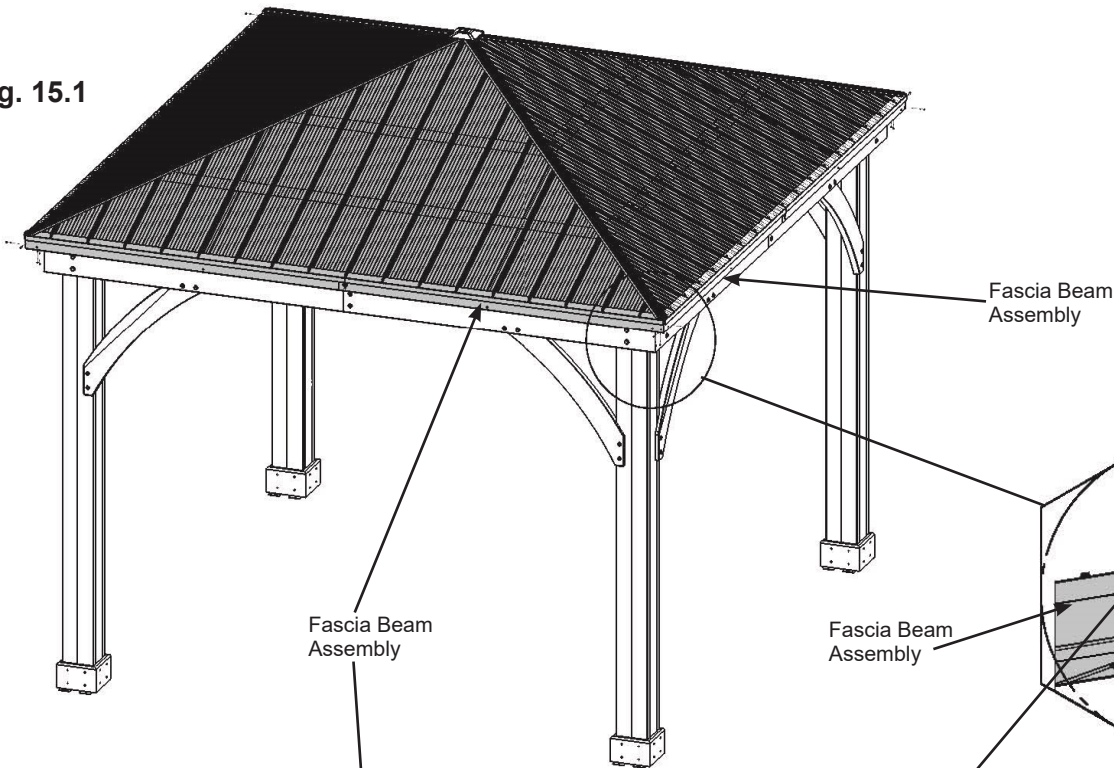


**A:** Make sure middle Roof to Beam Brackets are lined up over centre mark and all are flush and tight to the Beam Assemblies. Lift in centre if needed.

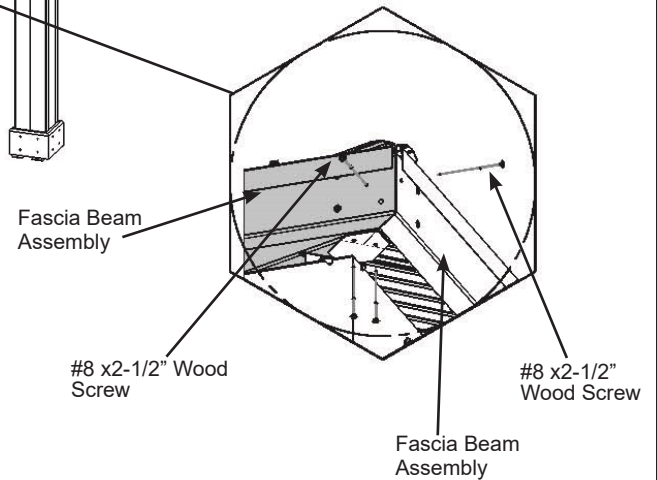
**B:** From outside the assembly attach Roof Panel Assemblies together at the Fascia Beam Assembly Ends with two #8 x 2-1/2" Wood Screws per corner. A helper may need to lift the centre of the roof to bring the corners tight together. (fig. 15.1 and 15.2)

**C:** Align Roof Panel Assemblies to sit centred on Roof to Post Brackets then attach with two #8 x 1" Pan Screws per bracket. (fig. 15.3)

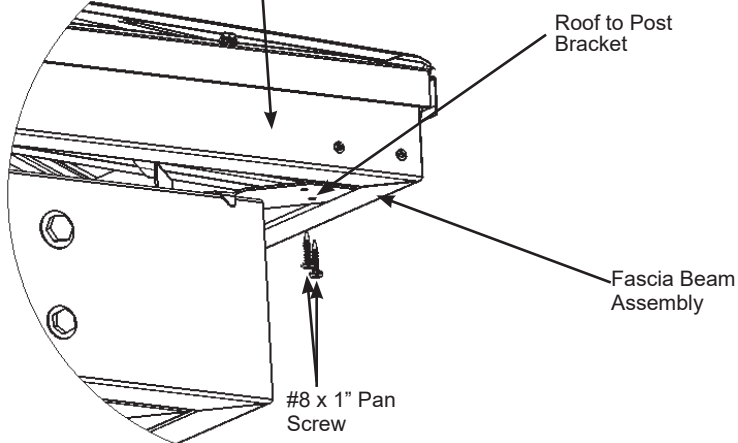
**Fig. 15.1**



**Fig. 15.2**



**Fig. 15.3**

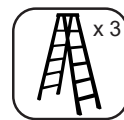


## Hardware

8 x #8 x 2-1/2" Wood Screw

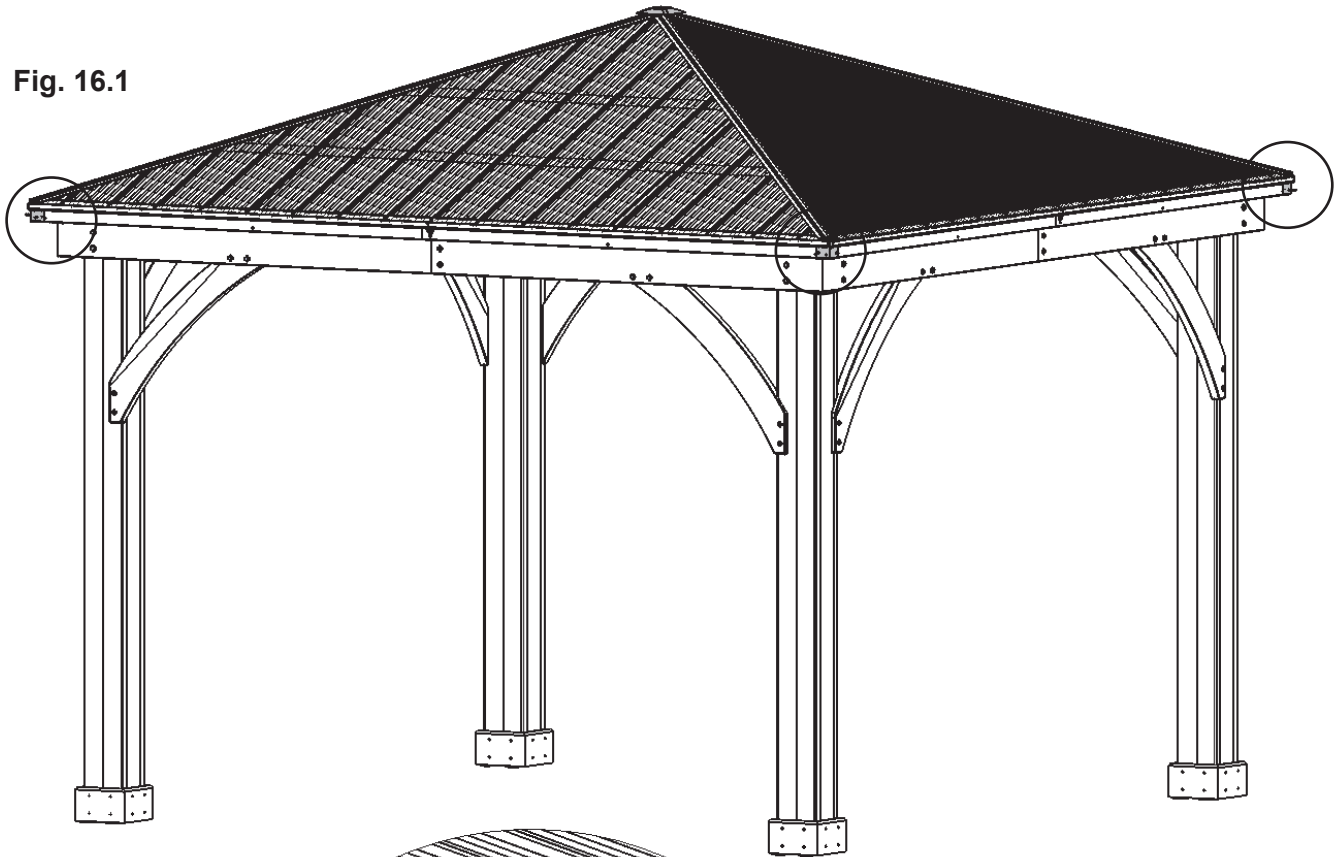
8 x #8 x 1" Pan Screw

# Step 16: Attach Corner and Beam Caps

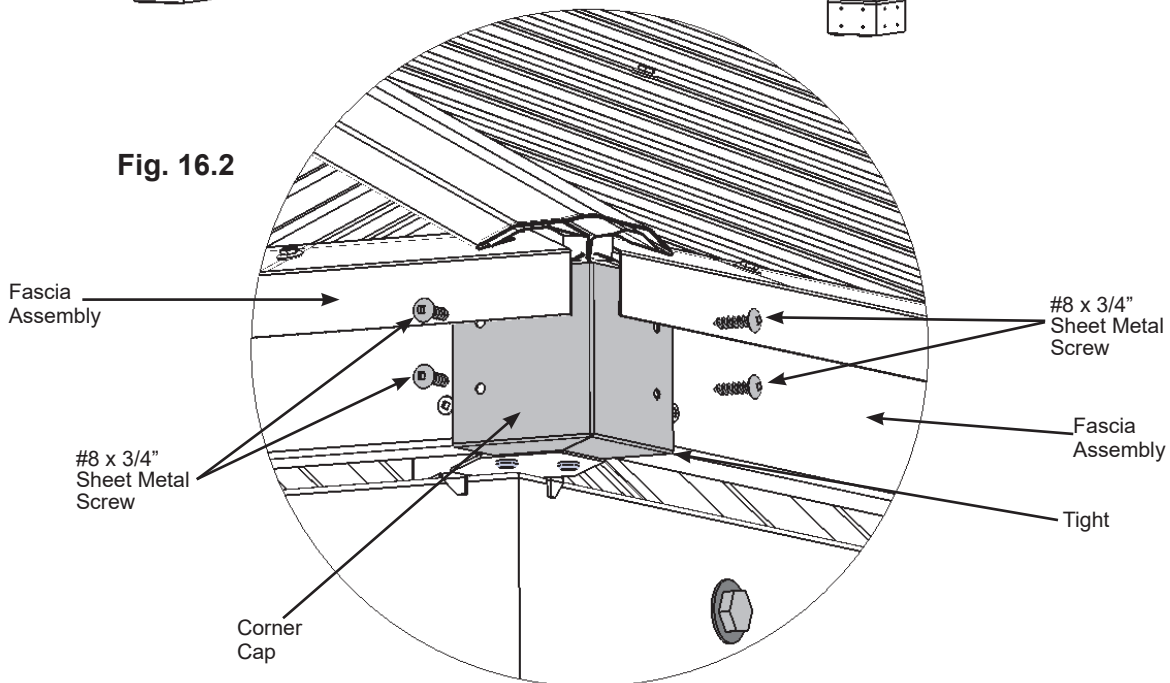


**A:** At each corner place one Corner Cap tight to Fascia Assemblies, push up so the bottom is tight to the bottom of the assemblies then attach with four #8 x 3/4" Sheet Metal Screws per Corner Cap. (fig. 16.1 and 16.2)

**Fig. 16.1**



**Fig. 16.2**



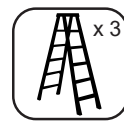
**Componets:**

4 x Corner Cap

**Hardware**

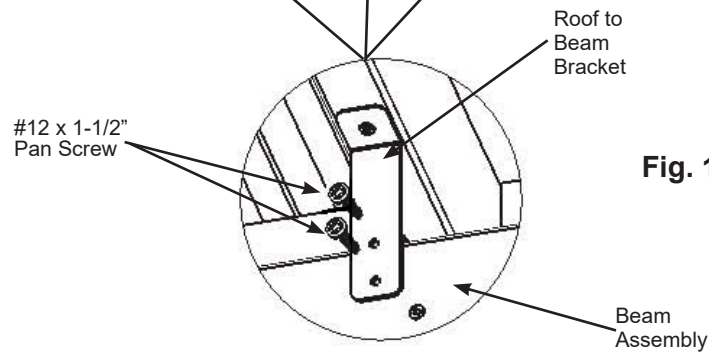
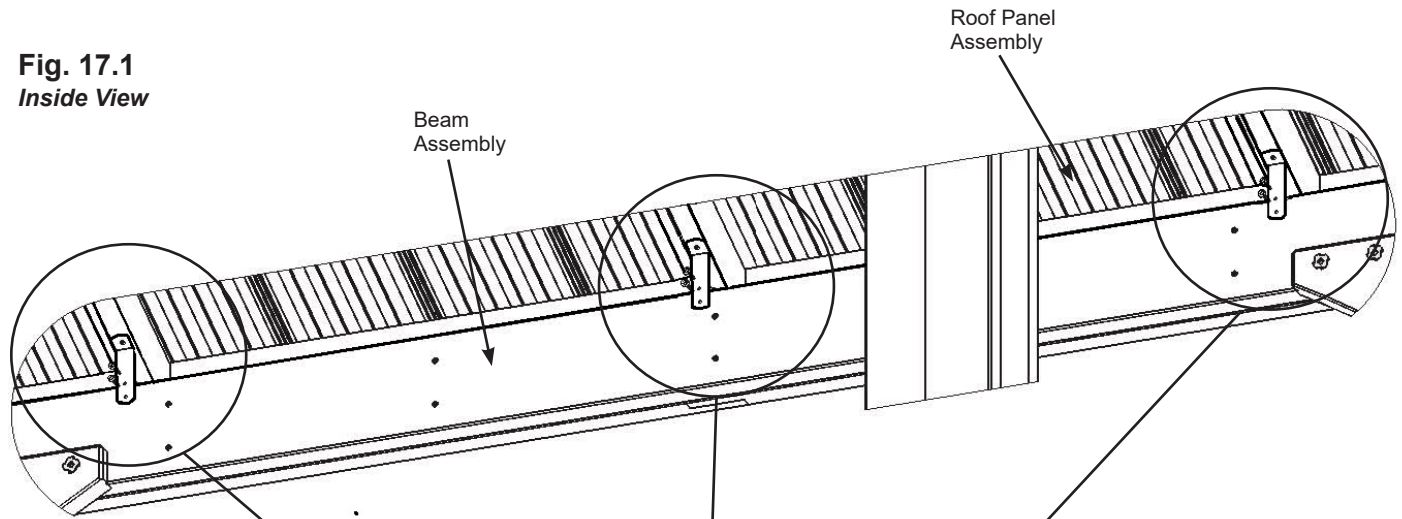
16 x #8 x 3/4" Sheet Metal Screw

# Step 17: Secure Roof to Beam Brackets



**A:** From inside the assembly attach Roof to Beam Brackets to Beam Assemblies with two #12 x 1-1/2" Pan Screws per bracket. (fig. 17.1 and 17.2)

**Fig. 17.1**  
*Inside View*



**Fig. 17.2**

### Hardware

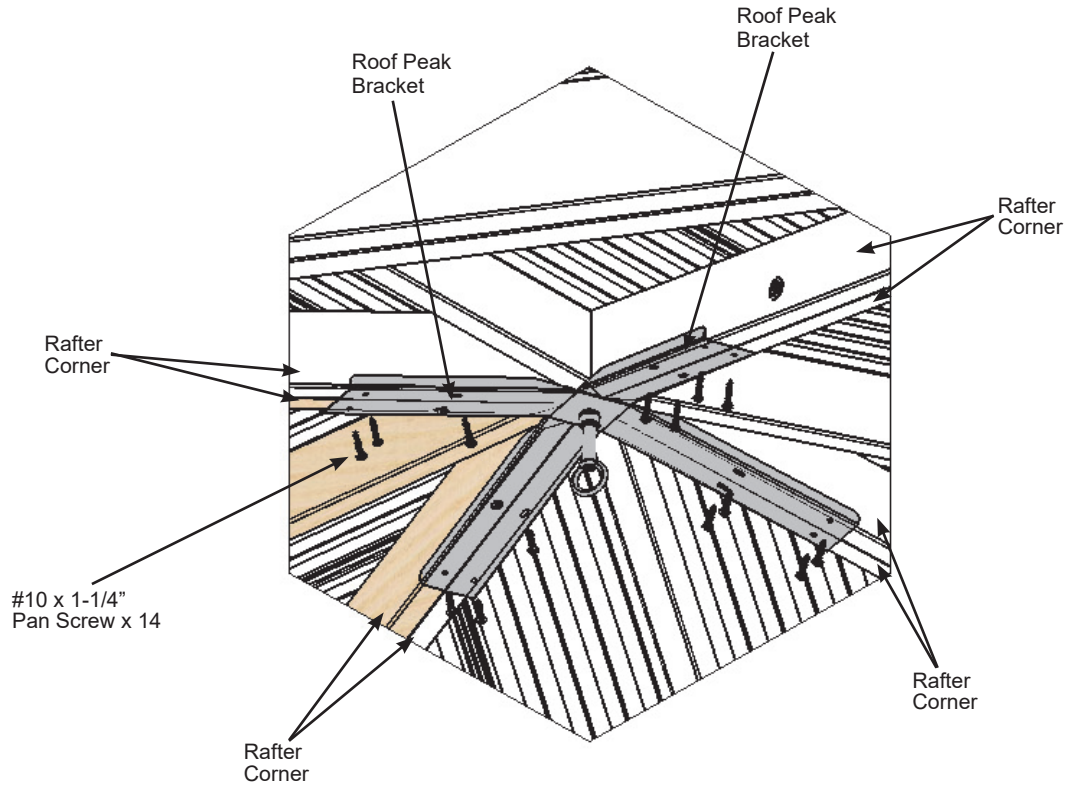
24 x #12 x 1-1/2" Pan Screw

# Step 18: Secure Roof Peak Brackets



**A:** Tighten the two screws in Roof Peak Brackets then attach to Corner Rafters in the remaining holes with fourteen #10 x 1-1/4" Pan Screws. (fig. 18.1)

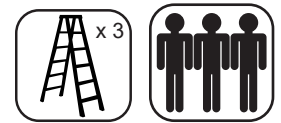
**Fig. 18.1**



**Hardware**

14 x #10 x 1-1/4" Pan Screw

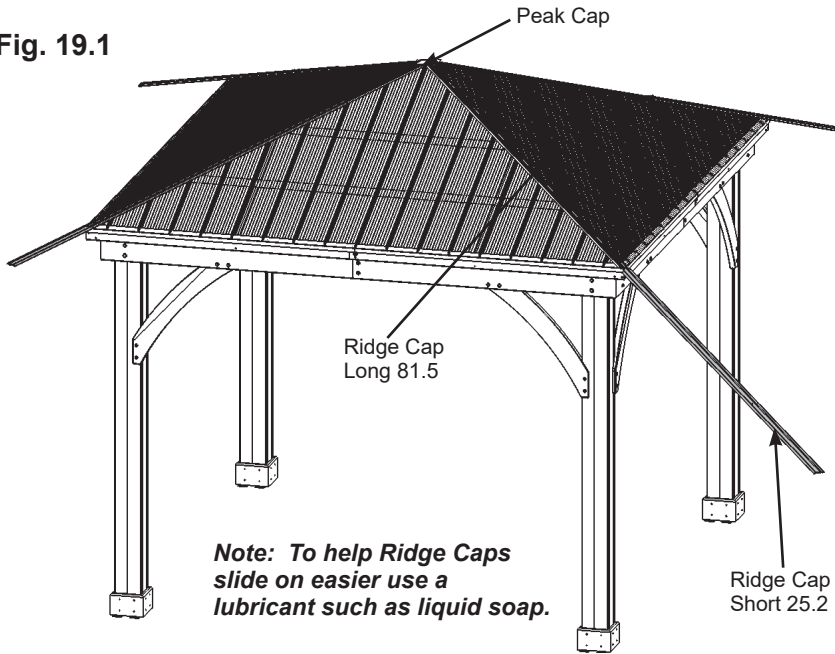
# Step 19: Attach Ridge Caps to Roof Panels



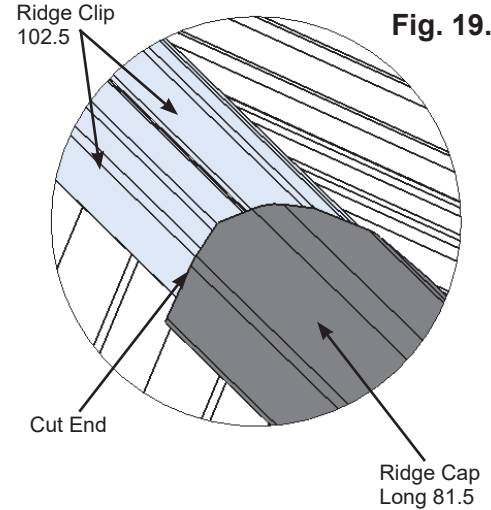
**A:** Slide one Ridge Cap Long 81.5 over the Ridge Clips, with cut end leading, on each corner of the assembly from the bottom up. Slide Ridge Cap Short 25.2 over the Ridge Clips leading with the insert end to push the Ridge Cap Long 81.5 to the top, lifting Peak Cap Long by pushing up the Peak Loop so Ridge Cap Long 81.5s fit under Peak Cap. Attach with two #8 x 3/4" Sheet Metal Screws per Ridge Cap set. (fig. 19.1, 19.2, 19.3, 19.4 and 19.5)

**B:** Tighten Loop to secure Roof Peak Set.

**Fig. 19.1**

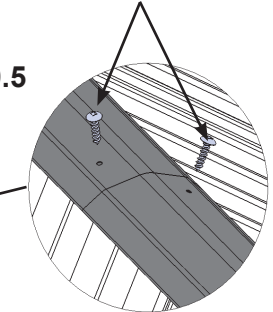


**Fig. 19.2**

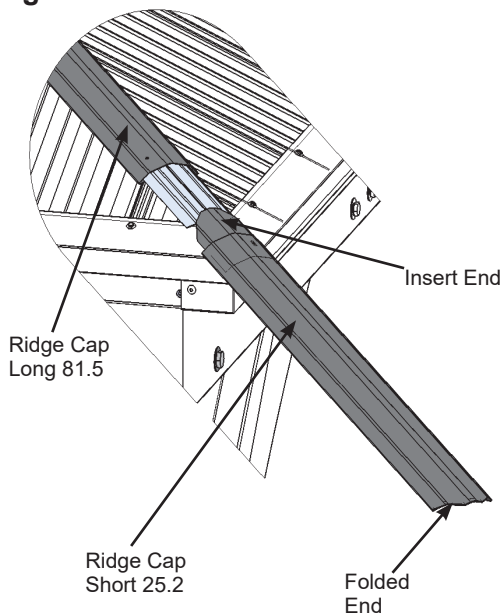


#8 x 3/4" Sheet Metal Screw

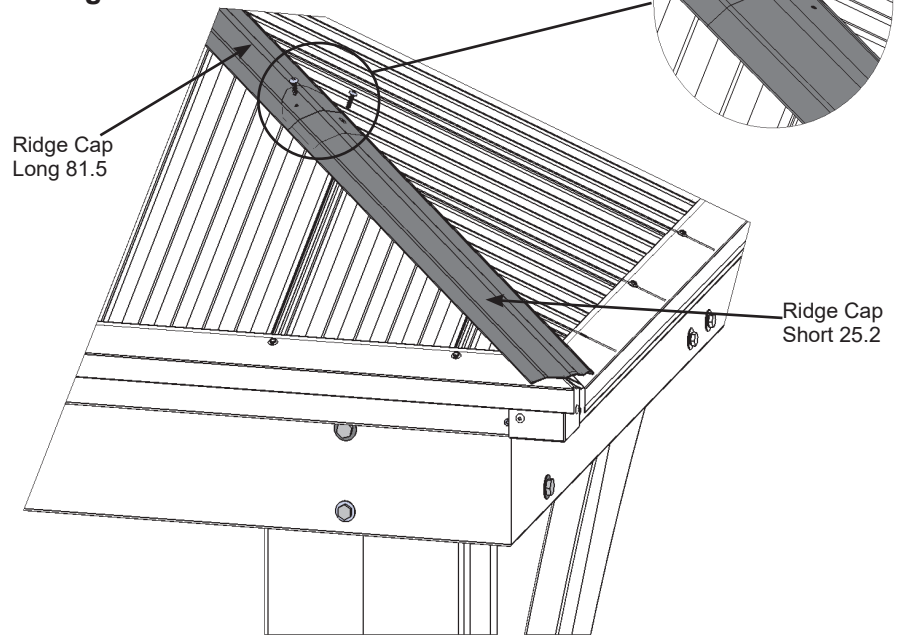
**Fig. 19.5**



**Fig. 19.3**



**Fig. 19.4**



**Components:**

- 4 x Ridge Cap Long 81.5
- 4 x Ridge Cap Short 25.2

**Hardware**

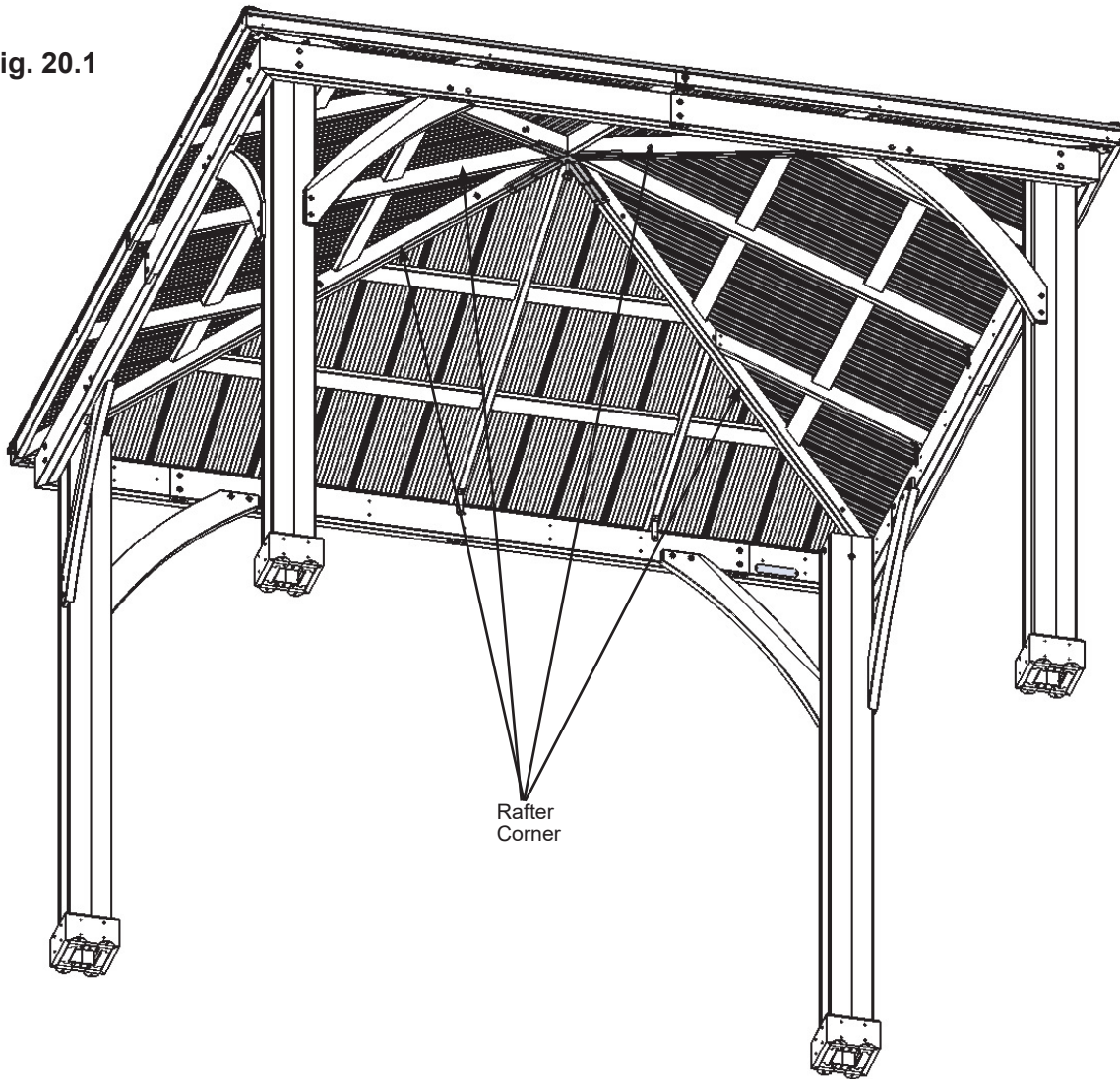
- 8 x #8 x 3/4" Sheet Metal Screw

# Step 20: Metal Hooks and Plaque Part 1



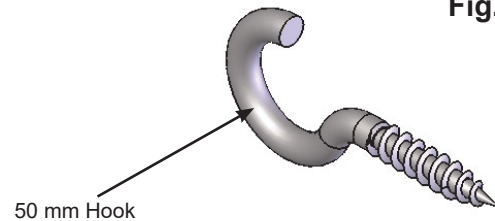
**A:** Two 50 mm Hooks are included with this unit for attaching wiring. They can be placed anywhere along the Rafter Corners as needed. Pre-drill with a 1/8" drill bit before installing. (fig. 20.1 and 20.2)

Fig. 20.1



**Note:** We have provided 2 hooks for optional use to hold in place any wires if required. These hooks are not designed to hold any heavy products such as lights, flower pots, etc.

Fig. 20.2



### Hardware

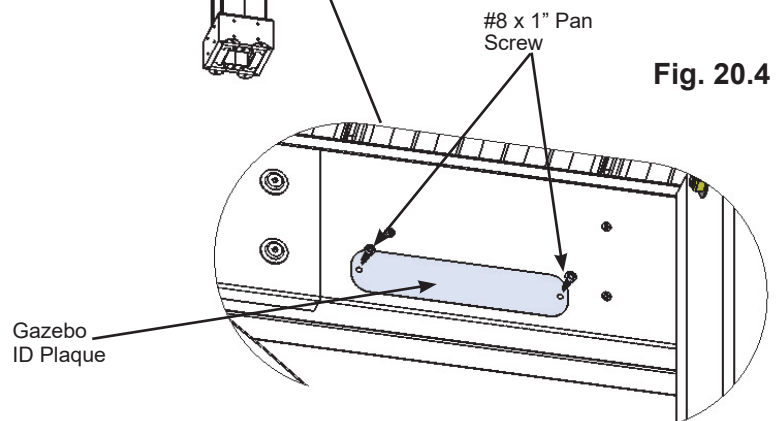
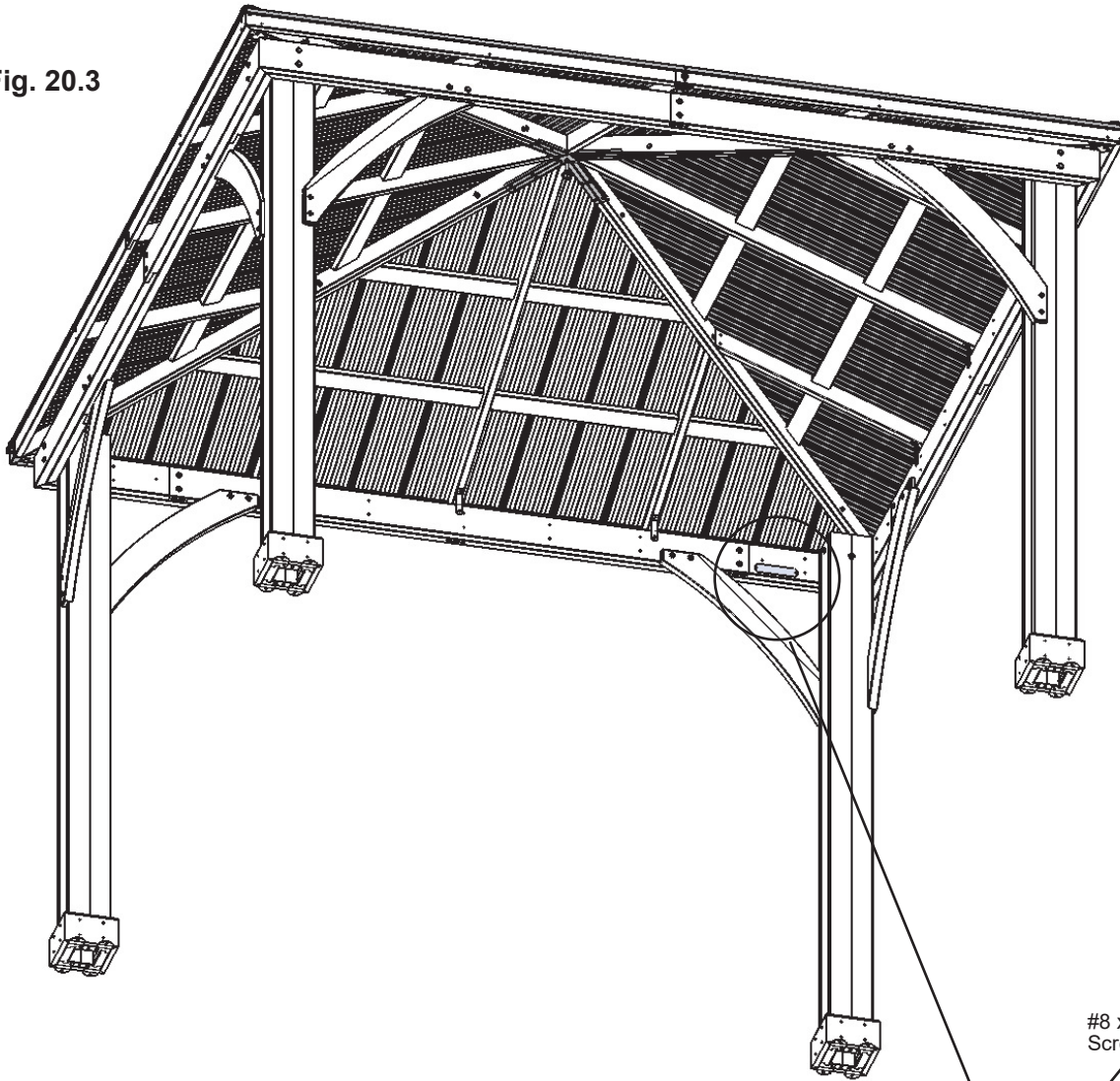
2 x 50 mm Hooks



## Step 20: Metal Hooks and Plaque Part 2

**B:** Attach Gazebo ID Plaque to a prominent location on your gazebo with two #8 x 1" Pan Screws. This provides warnings concerning safety and important contact information. A tracking number is provided to allow you to get critical information or order replacement parts for this specific model. (fig. 20.3 and 20.4)

Fig. 20.3



### Componets:

1 x Gazebo ID Plaque

### Hardware

2 x #8 x 1" Pan Screw

NOTES

---

---

---

---

---

---

---

---

---

---

---

---

---

---

---

---

---

---

---

---

---

---

---

---

---

---

## NOTES

---

---

---

---

---

---

---

---

---

---

---

---

---

---

---

---

---

---

---

---

---

---

---

---

---

---

---

---



## Customer Registration Card - Tarjeta de Registro del Cliente - Carte d'inscription du client

First Name - Primer Nombre - Prénom	Initial - Inicial - Initiale	Last Name - Apellido - Nom de famille

Street - Calle - Rue	PO Box - Casilla postal - Boîte postale	Apt. No. - App.

City - Ciudad - Ville	State/Province - Estado/Provincia - État/Province

ZIP/Postal Code - Código Postal - ZIP/Code postal	Country - País - Pays

E-mail Address - Dirección de E-mail - Adresse courriel	Telephone Number - No. de Teléfono - N° de téléphone

Model Name - Nombre del Modelo - Nom du modèle	Model Number (from front cover) - Número de Modelo (de la portada) - N° du modèle (page de couverture)

Date of Purchase - Fecha de Compra - Date d'achat (mm/dd/yyyy) (mm/dd/aaaa) (mm/jj/aaaa)	Place of Purchase - Comprado a - Lieu d'achat

Comments - Comentarios - Commentaires:

### Mail To - Enviar por Correo a - Envoyer par courrier à:

Yardistry  
375 Sligo Road West, PO Box 10  
Mount Forest, Ontario, Canada, N0G 2L0  
Attention: Consumer Relations  
Atención a: Servicio de Atención al Cliente  
À l'attention de: Service à la clientèle

### Online Registration - Registro online - Enregistrement en ligne:

[www.yardistrystructures.com/warranty](http://www.yardistrystructures.com/warranty)

Yardistry would like to say "Thank you" for your time and feedback.

Yardistry quiere "Agradecerle" por su tiempo y su opinión.

Yardistry aimerait vous remercier d'avoir pris le temps de répondre au sondage.

# 12' MERIDIAN PRIVACY WALL

Installation and Operating Instructions – YM11804

# PANEL DIVISORIO DE 12' MERIDIAN

Instrucciones de instalación y operación – YM11804

# MUR D'INTIMITÉ DE 12' MERIDIAN

Instructions d'installation et d'utilisation – YM11804

For use with the YM11769

12 x 12 Gazebo, YM11772

12 x 14 Gazebo, YM11915

12 x 16 Gazebo, YM11775

12 x 20 Gazebo and

YM11937 12 x 24 Gazebo

Para usar con el Gazebo

YM11769 12 x 12, Gazebo

YM11772 12 x 14, Gazebo

YM11915 12 x 16, Gazebo

YM11775 12 x 20 y Gazebo

YM11937 12 x 24

Pour utilisation avec le

Pavillon YM11769 12 x 12, le

Pavillon YM11772 12 x 14, le

Pavillon YM11915 12 x 16, le

Pavillon YM11775 12 x 20 et

le Pavillon YM11937 12 x 24



IMPORTANT, RETAIN FOR FUTURE REFERENCE: READ CAREFULLY

IMPORTANTE: CONSERVE PARA FUTURA REFERENCIA. LEA CUIDADOSAMENTE

IMPORTANT, À CONSERVER POUR DE FUTURS BESOINS DE RÉFÉRENCE : À LIRE SOIGNEUSEMENT

02-18-2022

# YARDISTRY®

Yardistry – North America  
Toll Free Customer Support: 1.888.509.4382  
info@yardistrystructures.com  
www.yardistrystructures.com

Yardistry – Norteamérica  
Línea gratuita de servicio al cliente: 1.888.509.4382  
info@yardistrystructures.com  
www.yardistrystructures.com

Yardistry – Amérique du Nord  
Service client sans frais: 1.888.509.4382  
info@yardistrystructures.com  
www.yardistrystructures.com

## Important Safety Notice!

Yardistry components are intended for privacy, decorative and ornamental use only.

### **Product is NOT INTENDED for the following:**

- A safety barrier to prevent unsupervised access to pools, hot tubs, spas or ponds.
- As load bearing support for a building, structure, heavy objects or swings.
- Used in structures that trap wind, rain or snow that would create extra load on the product.

**Permanent structures may require a building permit.** As the purchaser and or installer of this product you are advised to consult local planning, zoning and building inspection departments for guidance on applicable building codes and/or zoning requirements.

**Wood is NOT flame retardant and will burn.** Grills, fire pits and chimineas are a fire hazard if placed too close to a Yardistry structure. Consult user's manual of the grill, fire pit or chimenea for safe distances from combustible materials.

**Wear gloves to avoid injury** from possible sharp edges of individual elements before assembly.

**During installation, follow all safety warnings provided with your tools and use OSHA approved safety glasses.** Some structures may require two or more people to install safely.

**Check for underground utilities before digging or driving stakes into the ground!**

**It is important during assembly to closely follow the instructions,** complete the assembly on a solid level surface and that you follow the instruction to square up, level and anchor the structure, this will reduce the gap at wood connections during assembly.

This Privacy Wall is designed to enclose **ONE** side only. Installation of additional walls will reduce structural rigidity and is not recommended.

## Instructions for Proper Maintenance

Your Yardistry structure is designed and constructed of quality materials. As with all outdoor products it will weather and wear. To maximize the enjoyment, safety and life of your structure it is important that you, the owner, properly maintain it.

### **HARDWARE:**

- Check metal parts for rust. If found, sand and repaint using a non-lead paint complying with 16 CFR 1303.
- Inspect and tighten all hardware after completion of assembly; after first month of use; and then annually. Do not over-tighten as to cause crushing and splintering of wood.
- Check for sharp edges or protruding screw threads, add washers if required.

### **WOOD PARTS:**

- Applying a water repellent or stain (water-based) on a yearly basis is important maintenance to maintain maximum life and performance of the product.
- Check all wood members for deterioration, structural damage and splintering. Sand down splinters and replace deteriorated wood members. As with all wood, some checking and small cracks in grain is normal
- Some gapping may occur at some wood connections.

### **Tools Required:**

- |                              |                  |                       |                |
|------------------------------|------------------|-----------------------|----------------|
| • Standard or Cordless Drill | • Safety Glasses | • Tape Measure        | • 9/16" Wrench |
| • 6' Step Ladder             | • Ratchet        | • 1/2" & 9/16" Socket | • Square       |
|                              |                  |                       | • Adult Helper |

**If you dispose of your Yardistry structure:** Please disassemble and dispose of your unit so that it does not create any unreasonable hazards at the time it is discarded. Be sure to follow your local waste ordinances.

## ¡Nota importante de seguridad!

Los componentes Yardistry están hechos para brindar privacidad y usarse de forma decorativa y ornamental.

### El producto NO TIENE COMO PROPÓSITO lo siguiente:

- Ser usado como barrera de seguridad para evitar el acceso no supervisado a piscinas, jacuzzis, spas o estanques.
- Ser usado como soporte para un edificio, estructura, objetos pesados o columpios.
- Ser usado en lugares donde haya acumulación de viento, lluvia o nieve que genere una carga adicional al producto.

**Las estructuras permanentes pueden requerir un permiso de construcción.** Como comprador e instalador de este producto se recomienda consultar con los departamentos de planificación, zonificación e inspección de construcción local para guías o códigos de construcción aplicables y/o requisitos de zonificación.

**La madera NO es un retardante de incendios y se prende fuego.** Las parrillas, fosas para fogatas y chimeneas son un peligro de incendio si se colocan muy cerca de una estructura Yardistry. Consulte en el manual del usuario de la parrilla, fosa para fogata o chimenea las distancias seguras de materiales inflamables.

**Use guantes para evitar lastimarse** con los posibles bordes filosos de las piezas antes del montaje.

**Durante el montaje, siga todas las advertencias de seguridad proporcionadas con sus herramientas y use gafas de seguridad aprobadas por la OSHA.** Algunas estructuras pueden requerir de dos o más personas para un montaje seguro.

**¡Revise si hay servicios básicos bajo tierra antes de cavar o clavar estacas en el suelo!**

**Durante el montaje, es importante seguir estas instrucciones al pie de la letra,** que el montaje se realice sobre una superficie sólida y nivelada y que se sigan las instrucciones para encuadrar, nivelar y anclar la estructura para reducir las separaciones entre las maderas.

Este panel divisorio está diseñado para encerrar UN solo lado. La instalación de paneles adicionales reducirá la rigidez estructural y no se recomienda.

## Instrucciones para el mantenimiento correcto

Su estructura Yardistry está diseñada y construida con materiales de calidad. Como todos los productos para exteriores se erosiona y desgasta. Para maximizar el placer, seguridad y vida útil de su estructura es importante que usted, el dueño, le dé el mantenimiento apropiado.

### TORNILLOS Y ACCESORIOS:

- Revise si están oxidadas las partes metálicas. Si se encuentra alguna, líjela y vuélvala a pintar usando pintura sin plomo que cumpla con el 16 CFR 1303.
- Inspeccione y ajuste todos los tornillos y accesorios al finalizar el montaje; después del primer mes de uso; y luego, anualmente. No ajuste los tornillos de más ya que puede romper y astillar la madera.
- Verifique si hay bordes filosos o tornillos sobresalidos, agregue arandelas si es necesario.

### PIEZAS DE MADERA:

- Sin protección lucirán desgastadas con el tiempo. La aplicación periódica de una pintura externa impermeabilizante (a base de agua) ayudará a mejorar la apariencia y duración.
- Revise si hay deterioro, daño estructural o astillado en todas las piezas de madera. Lije las astillas y remplace los tornillos y accesorios de madera deteriorados. Como con todas las maderas, es normal que tengan marcas y pequeñas grietas en pequeñas cantidades.
- Puede haber separaciones entre las uniones de algunas maderas.

### Herramientas requeridas:

- |                                |                      |                         |                   |
|--------------------------------|----------------------|-------------------------|-------------------|
| • Taladro estándar o sin cable | • Gafas de seguridad | • Cinta métrica         | • Llave 9/16"     |
| • Escalera de 6'               | • Trinquete          | • Tubos de 1/2" y 9/16" | • Escuadra        |
|                                |                      |                         | • Ayudante adulto |

**Si se deshace de su estructura Yardistry:** Por favor desarme y deshágase de su unidad de manera de no generar riesgos innecesarios el momento de desecharla. Asegúrese de cumplir con las ordenanzas locales de eliminación.

## Avis important de sécurité!

Les composantes Yardistry sont conçues uniquement pour des fins d'intimité, de décoration et d'ornementation.

### Le produit N'EST PAS CONÇU pour les usages suivants:

- Barrière de sécurité pour empêcher l'accès à des piscines, spas ou étangs.
- Support structural pour bâtiment, structure, objet lourd ou balançoire.
- Utilisation en tant que structure brise-vent, ou servant à accumuler la pluie ou la neige, ce qui créerait une charge supplémentaire sur le produit.

**Des structures permanentes pourraient nécessiter un permis.** En tant qu'acheteur ou installateur de ce produit, nous vous conseillons de consulter les départements locaux d'urbanisme, de zonage, et d'inspection de bâtiments pour les indications relatives au code du bâtiment et aux exigences de zonage.

**Le bois n'est PAS ignifuge et peut s'enflammer.** Les barbecues, foyers extérieurs et cheminées représentent un risque d'incendie s'ils sont situés trop près de la structure Yardistry. Consultez le manuel d'utilisation du barbecue, foyer extérieur ou de la cheminée pour connaître les distances sécuritaires pour les matériaux combustibles.

**Portez des gants pour éviter les blessures** pouvant être causées par les bordures tranchantes des éléments individuels avant l'assemblage.

**Lors de l'installation, respectez toutes les normes de sécurité de vos outils et portez des lunettes de protection certifiées par l'OHSA.** Certaines structures pourraient nécessiter l'aide de deux personnes ou plus pour une installation sécuritaire.

**Vérifiez les installations souterraines avant de creuser ou de forer!**

**Pendant l'assemblage, il est important de suivre attentivement les instructions,** d'effectuer l'assemblage sur une surface solide et de niveau, et de respecter les instructions d'alignement, de mise à niveau et d'ancrage, afin de minimiser les espacements entre les joints de bois pendant l'assemblage.

Ce mur d'intimité est conçu pour fermer UN côté seulement. L'installation de murs supplémentaires pourrait réduire la rigidité structurelle et n'est pas recommandée.

## Instructions pour un entretien adéquat

Votre structure Yardistry est conçue et fabriquée à l'aide de matériaux de qualité. Comme pour tous les produits d'extérieur, elle sera soumise au climat et à l'usure. Afin de maximiser l'utilisation, la sécurité et la durée de vie de votre structure, il est important que vous l'entretenez adéquatement.

### QUINCAILLERIE:

- Assurez-vous qu'aucune rouille n'est présente. Si c'est le cas, sablez et repeignez à l'aide de peinture sans plomb respectant la norme 16 CFR 1303.
- Inspectez et resserrez toute la quincaillerie après l'assemblage; après le premier mois d'usage; et ensuite annuellement. Ne pas trop serrer afin de ne pas écraser ou fendiller le bois.
- Assurez-vous qu'aucune bordure coupante ou filet de vis ne dépasse, ajoutez des rondelles si nécessaire.

### PIÈCES DE BOIS:

- L'application d'une teinture ou d'un scellant imperméabilisant (à base d'eau) sur une base annuelle constitue un entretien important pour une durée de vie et une résistance accrues du produit.
- Assurez-vous qu'il n'existe pas de détérioration, de dommage structurel ou d'éclats de bois. Sablez les éclats de bois et remplacez les pièces de bois détériorées. Comme pour toute structure en bois, quelques craquelures et de petits fendillements dans le bois sont normaux.
- Certains espacements pourraient être présents entre certains joints de bois.

### Outils nécessaires:

- |                                 |                        |                        |                    |
|---------------------------------|------------------------|------------------------|--------------------|
| • Perceuse standard ou sans fil | • Lunettes de sécurité | • Ruban à mesurer      | • Clé 9/16"        |
| • Échelle de 6'                 | • Clé à rochet         | • Douille 1/2" & 9/16" | • Équerre          |
|                                 |                        |                        | • Assistant adulte |

**Si vous jetez une structure Yardistry:** Veuillez démonter et jeter l'unité de façon à ne pas créer de risque excessif au moment de l'élimination. Assurez-vous de respecter vos normes locales de mise aux rebuts.



## General Information

Wood components are manufactured with Cedar (C. Lanceolata) which is protected with factory applied water-based stain. Knots, small checks (cracks) and weathering are naturally occurring and do not affect the strength of the product. Annual application of a water-based water repellent sealant or stain is important and will help reduce weathering and checks.

**[www.yardistrystructures.com](http://www.yardistrystructures.com)**

Questions?

Call toll free or write us at:  
1 (888) 509-4382  
[support@yardistrystructures.com](mailto:support@yardistrystructures.com)

Patents Pending

## Información General

Los componentes de madera son fabricados con cedro (C. Lanceolata) y vienen protegidos de fábrica con pintura base de agua. Es normal la aparición de nudos, pequeñas marcas (grietas) y el desgaste y no afectan la resistencia del producto. Es importante aplicar todos los años un sellador o barniz impermeabilizante a base de agua para reducir el desgaste y agrietamiento de la madera.

**[www.yardistrystructures.com](http://www.yardistrystructures.com)**

¿Preguntas?

Llame a nuestra línea gratuita o escríbanos a:  
1 (888) 509-4382  
[support@yardistrystructures.com](mailto:support@yardistrystructures.com)

Patentes pendientes

## Information Générale

Les composantes en bois sont fabriquées en cèdre et sont protégées à l'aide d'une teinture à base d'eau appliquée en usine. Les noeuds, petites fissures et craquelures ainsi que les altérations atmosphériques sont des phénomènes naturels, et n'affectent pas la solidité du produit. Il est important d'appliquer annuellement une teinture ou un scellant imperméabilisant à base d'eau, afin de limiter l'usure et les fissures.

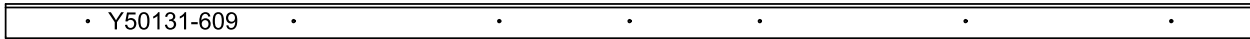
**[www.yardistrystructures.com](http://www.yardistrystructures.com)**

Questions?

Appelez-nous sans frais ou écrivez-nous au:  
1 (888) 509-4382  
[support@yardistrystructures.com](mailto:support@yardistrystructures.com)

Brevets en instance

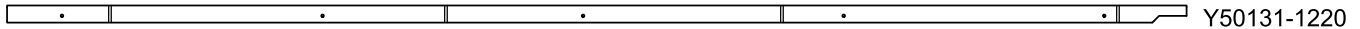
**1pc.** (609) Ground / Base 609) / Sol (609) - 91" (2311.4mm)



**2pc.** (1219) Middle Support / Soporte Medio (1219) / Support central (1219) - 86" (2184.4mm)



**2pc.** (1220) Post Support / Soporte del Poste (1220) / Support de montant (1220) - 86" (2184.4mm)



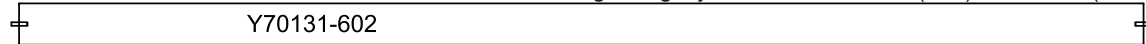
**1pc.** (610) Right End Ground / Base Derecha (610) / Sol droit (610) - 13-3/8" (339.7mm)



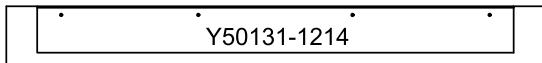
**1pc.** (611) Left End Ground / Base Izquierda (611) / Sol gauche (611) - 13-3/8" (339.7mm)



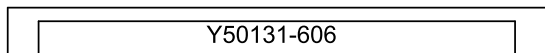
**3pc.** (602) Frame Centre Dowel Assembly / Ensamble de la Tabla Central del Marco (602) / Assemblage de goujon central de cadre (602) - 83-1/8" (2111.3mm)



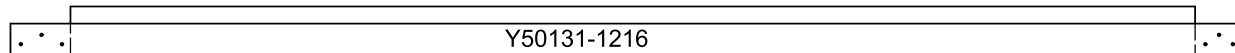
**3pc.** (1214) Frame Top / Tabla Superior del Marco (1214) / Dessus de cadre (1214) - 39-1/4" (996.8mm)



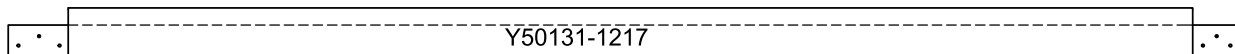
**3pc.** (606) Bottom Frame / Tabla Inferior del Marco (606) / Cadre inférieur (606) - 39-1/4" (996.8mm)



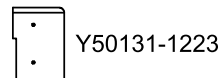
**3pc.** (1216) Post Left / Poste Izquierdo (1216) / Montant gauche (1216) - 89-7/8" (2282.8mm)



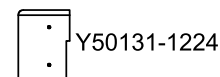
**3pc.** (1217) Post Right / Poste Derecho (1217) / Montant droit (1217) - 89-7/8" (2282.8mm)



**1pc.** (1223) Inside Left Plinth / Plinto Interior Izquierdo (1223) / Plinthe intérieure gauche (1223) - 3-3/4" (95.3mm)



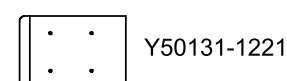
**1pc.** (1224) Inside Right Plinth / Plinto Interior Derecho (1224) / Plinthe intérieure droite (1224) - 3-3/4" (95.3mm)



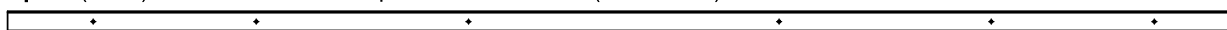
**1pc.** (1222) Left Outside Plinth / Plinto Exterior Izquierdo (1222) / Plinthe extérieure gauche (1222) - 7-3/4" (196.9mm)



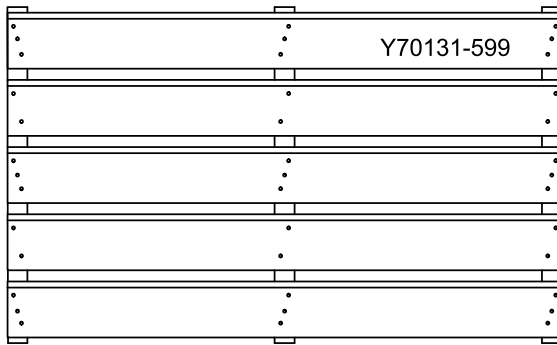
**1pc.** (1221) Right Outside Plinth / Plinto Exterior Derecho (1221) / Plinthe extérieure droite (1221) - 7-3/4" (196.9mm)



**2pc.** (1225) Filler / Relleno / Remplisseur - 89-7/8" (2282.8mm) Y50131-1225

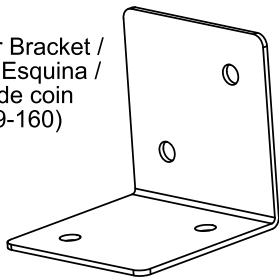


**12pc. (599) Louvered Panel / Ensemble del Panel Apersianado (599) / Assemblage de panneau de persienne (599)**

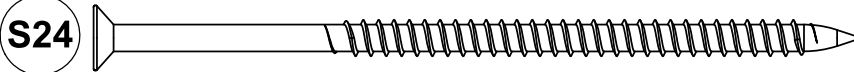


- 34-5/8" (880mm)

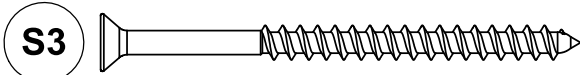
**2pc. Corner Bracket /  
Soporte de Esquina /  
Équerre de coin  
(Y00419-160)**



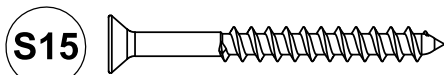
**10pc - Wood Screw / Tornillo para madera / Vis à bois #10 x 4" - (Y06091-740)**



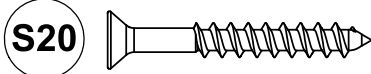
**31pc - Wood Screw / Tornillo para madera / Vis à bois #8 x 2 1/2" - (Y06091-522)**



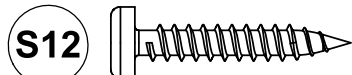
**144pc - Wood Screw / Tornillo para madera / Vis à bois #8 x 1-3/4" (Y06091-513)**



**36pc. - Wood Screw / Tornillo para madera / Vis à bois #8 x 1-3/8" (Y06091-516)**

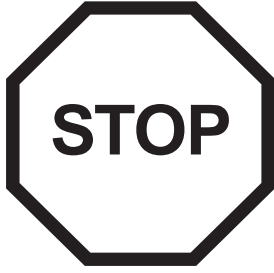


**4pc. - Pan Screw / Tornillo de cabeza plana / Vis à tête cylindrique #10 x 1-1/4" (Y06491-711)**



**1pc. #2 x 2" (Y00400-005)  
Robertson Driver /  
Destornillador Robertson /  
Mèche Robertson**

# Step 1: Inventory Parts - Paso 1: Piezas del inventario - Étape 1 : Inventaire des pièces



**A.** This is the time for you to inventory all your hardware and components referencing the parts identification sheets. This will assist you with your assembly.

- Each step indicates what you will need for assembly.

**B.** If there are any missing or damaged pieces or you need assistance with assembly please contact the consumer relations department directly. Call us before going back to the store.

**C.** Read the assembly manual completely, following the instructions in order.

**A.** Este es el momento en que debe hacer el inventario de todos los tornillos y accesorios consultando las hojas de identificación de piezas. Esto lo ayudará en el montaje.

- Cada paso indica los pernos y/o tornillos que necesitará para el montaje.

**B.** Si hay alguna pieza que falte o esté dañada, o si necesita ayuda con el montaje, por favor contáctese directamente con el departamento de atención al cliente. Llámenos antes de regresar a la tienda.

**C.** Lea todo el manual de instalación. Siga las instrucciones en orden.

**A.** Il est temps pour vous de faire l'inventaire de toute la quincaillerie et des accessoires présentés sur les pages d'identification. Cela vous facilitera la tâche d'assemblage.

- Chaque étape indique ce dont vous avez besoin pour l'assemblage.

**B.** Si des pièces sont manquantes ou endommagées, ou si vous avez besoin d'assistance pour l'assemblage, contactez le département des relations avec la clientèle directement. Appelez-nous avant de retourner en magasin

**C.** Lisez la totalité du manuel d'assemblage. Suivez les instructions dans l'ordre.

**1-888-509-4382**  
**support@yardistrystructures.com**

**YM11804**

CARTON I.D. STAMP: / No. ID DE LA CAJA: / IDENTIFIANT DE BOÎTE:

— — — — —

## Step 2: Frame Assembly Part 1 - Paso 2: Ensamble del marco Parte 1 - Étape 2 : Assemblage de cadre Partie 1

**A:** On a flat surface lay out one (1214) Frame Top and one (606) Bottom Frame then place one (1216) Post Left and one (1217) Post Right on each end so the ends and sides are flush. (F2.1)

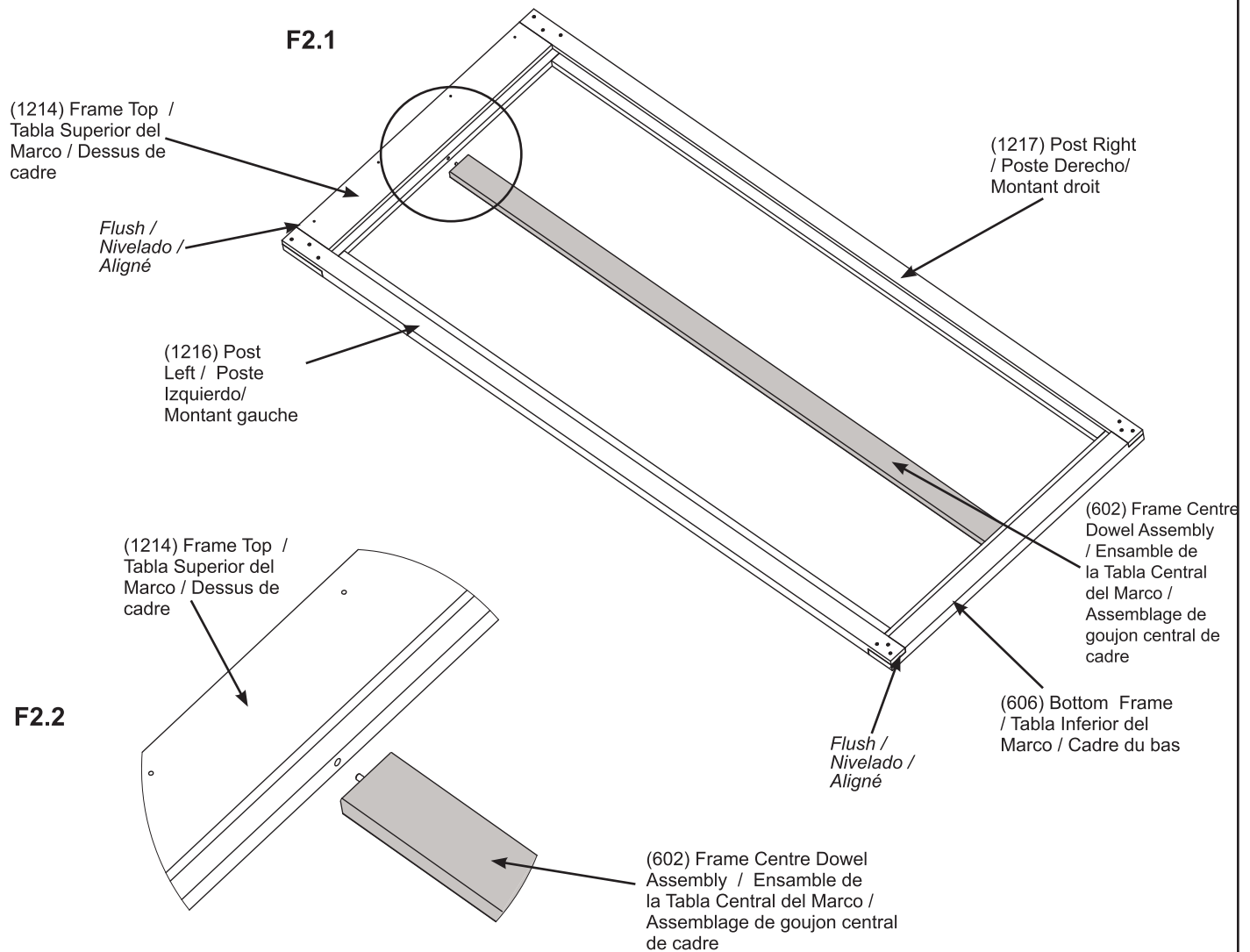
**B:** Insert (602) Frame Centre Dowel Assembly in between (1214) Frame Top and (606) Bottom Frame in the centre holes. (F2.1 and F2.2)

**A:** Sobre una superficie plana, coloque una Tabla Superior del Marco (1214) y una Tabla Inferior del Marco (606) y luego coloque un Poste Izquierdo (1216) y un Poste Derecho (1217) en cada extremo de manera que los lados queden nivelados. (F2.1)

**B:** Inserte el Ensamble de la Tabla Central del Marco (602) entre la Tabla Superior del Marco (1214) y la Tabla Inferior del Marco (606) en los agujeros centrales. (F2.1 y F2.2)

**A:** Sur une surface plane, disposez un Dessus de cadre (1214) et un Cadre inférieur (606) puis placez un Montant gauche (1216) et un Montant droit (1217) à chaque extrémité, de façon à ce que les extrémités et les côtés soient alignés. (F2.1)

**B:** Insérez l'assemblage de goujon central de cadre (602) entre le Dessus de cadre (1214) et le Cadre inférieur (606) dans les orifices du centre. (F2.1 et F2.2)



### Wood / Madera / Bois

3 x (1214) Frame Top / Tabla Superior del Marco / Dessus de cadre

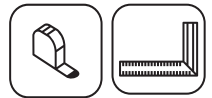
3 x (606) Bottom Frame / Tabla Inferior del Marco / Cadre inférieur

3 x (1216) Post Left / Poste Izquierdo / Montant gauche

3 x (1217) Post Right / Poste Derecho / Montant droit

3 x (602) Frame Centre Dowel Assembly / Ensamble de la Tabla Central del Marco / Assemblage de goujon central de cadre

## Step 2: Frame Assembly Part 2 - Paso 2: Ensamble del marco Parte 2 - Étape 2 : Assemblage de cadre Partie 2



**C:** Make sure tops, bottoms and sides of (1216) Post Left and (1217) Post Right are flush and square to (1214) Frame Top and (606) Bottom Frame then attach with three (S20) Wood Screws per corner. (F2.3, F2.4 and F2.5)

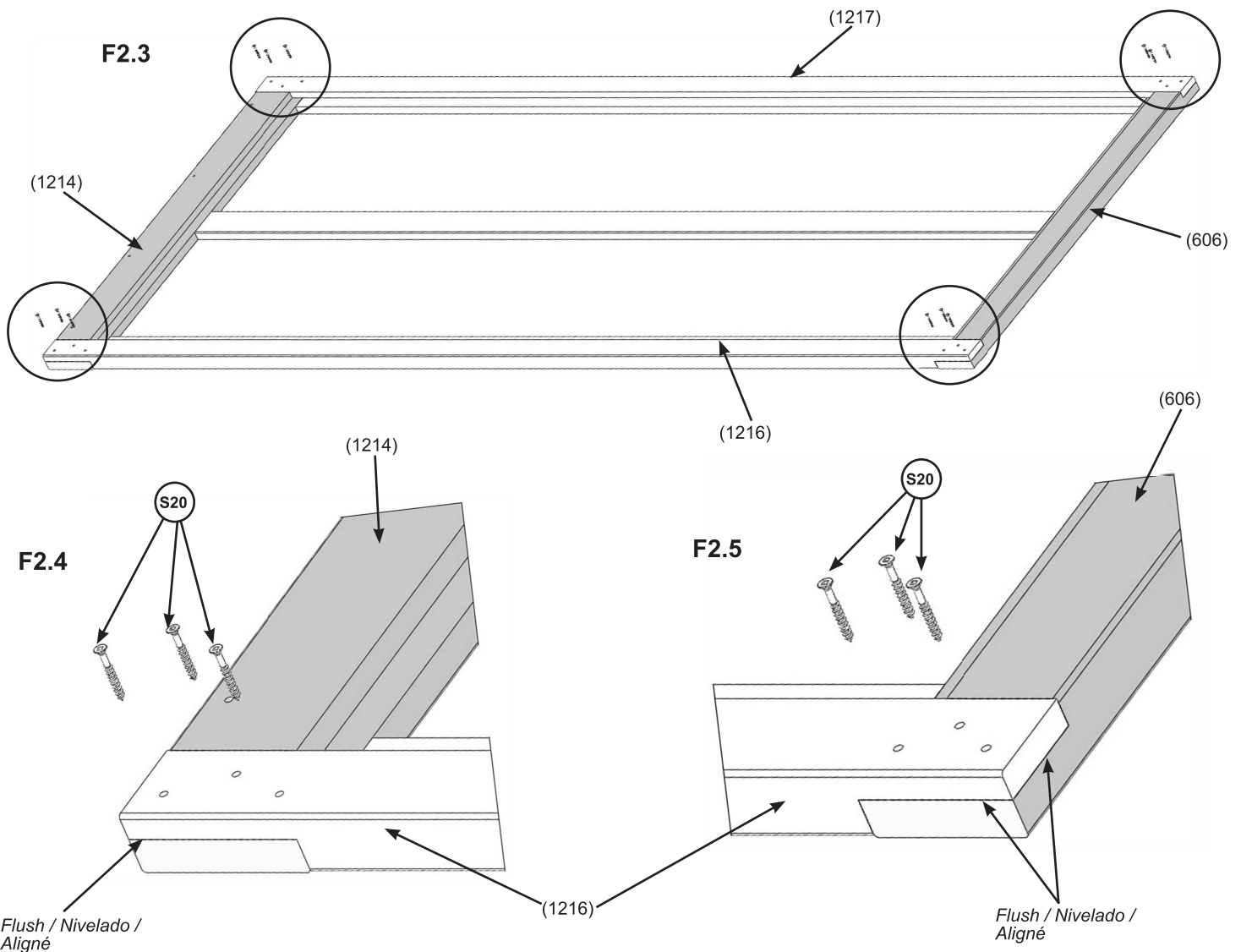
**D:** Repeat A-C for two more assemblies. There will be three in total.

**C:** Asegúrese de que las puntas, bases y laterales del Poste Izquierdo (1216) y el Poste Derecho (1217) estén nivelados y en escuadra con la Tabla Superior del Marco (1214) y la Tabla Inferior del Marco (606) y luego fíjelos con tres Tornillos para madera (S20) por esquina. (F2.3, F2.4 y F2.5)

**D:** Repita los pasos A-C para armar dos ensambles más. Debe haber tres en total.

**C:** Assurez-vous que le haut, le bas et les côtés du Montant gauche (1216) et du Montant droit (1217) sont alignés et d'équerre avec le Dessus de cadre (1214) et le Cadre inférieur (606), puis fixez avec trois Vis à bois (S20) par coin. (F2.3, F2.4 et F2.5)

**D:** Répétez les étapes A-C pour créer deux assemblages de plus. Il y en aura trois au total.



### Hardware / Tornillos y accesorios / Quincaillerie

36 x (S20) #8 x 1-3/8"

## Step 2: Frame Assembly Part 3 - Paso 2: Ensamble del marco Parte 3 - Étape 2 : Assemblage de cadre Partie 3

**Only complete Step E for installation on a 12 x 12 Gazebo.**

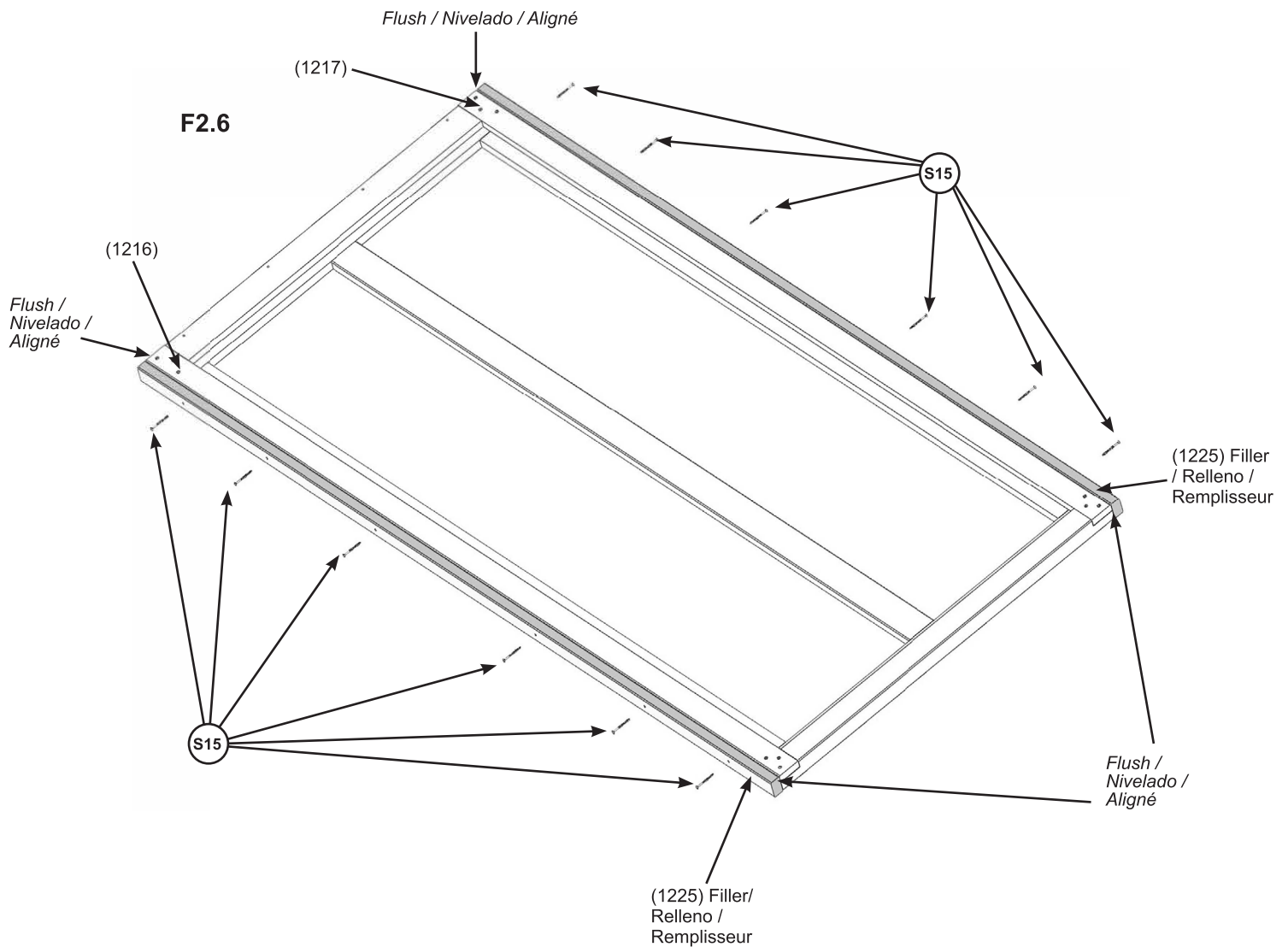
**E:** On one Frame Assembly place one (1225) Filler to both (1216) Post Left and (1217) Post Right, flush to the ends, tops and bottoms, then attach with six (S15) Wood Screws per side. (F2.6)

**Solo complete el paso E para instalación en un Gazebo 12 x 12.**

**E:** En uno ensamble del marco coloque uno Relleno (1225) a ambos poste izquierdo (1216) y poste derecho (1217), nivelado con los bordes, en las partes superior y inferior, luego fíjelo con seis tornillos para madera (S15) por lado. (F2.6)

**Complétez l'étape E uniquement pour une installation sur un Pavillon 12 x 12.**

**E:** Sur un assemblage de cadre, placez un Remplisseur (1225) sur chaque Montant gauche (1216) et Montant droit (1217) aligné avec les extrémités, en haut et en bas, puis fixez avec six vis à bois (S15) par côté. (F2.6)



### Wood / Madera / Bois

2 x (1225) Filler / Relleno / Remplisseur

### Hardware / Tornillos y accesorios / Quincaillerie

12 x (S15) #8 x 1-3/4"

# Step 3: Prepare Gazebo Part 1 - Paso 3: Preparación del Gazebo Parte 1 - Étape 3 :Préparation du gazebo Partie 1

**A:** On one Beam Assembly for the 12 x 12 Gazebo and one Short Beam Assembly for all other Gazebos, remove both Gussets from Post and Beam Assemblies. (F3.1 and F3.2)

**B:** On the same wall, remove one front and side Plinth from each Post Assembly. (F3.1 and F3.3)

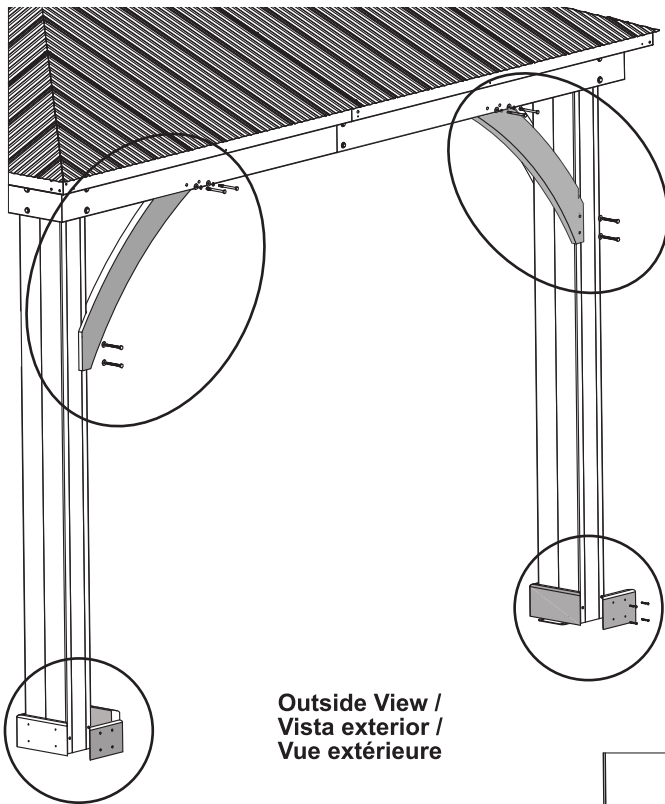
**A:** En uno Ensemble de Viga del Gazebo de 12 x 12 y un Ensemble de Viga Corta de todos los otros Gazebos, retire ambos Refuerzos de los Ensamblajes de Poste y Viga. (F3.1 y F3.2)

**B:** En la misma pared, retire un Plinto delantero y lateral de cada Ensemble de Poste. (F3.1 y F3.3)

**A:** Sur un Assemblage de poutre pour le Pavillon 12 x 12 et un Assemblage de poutre courte pour tous les autres Pavillons, retirez les deux goussets des assemblages de montant et de poutre. (F3.1 et F3.2)

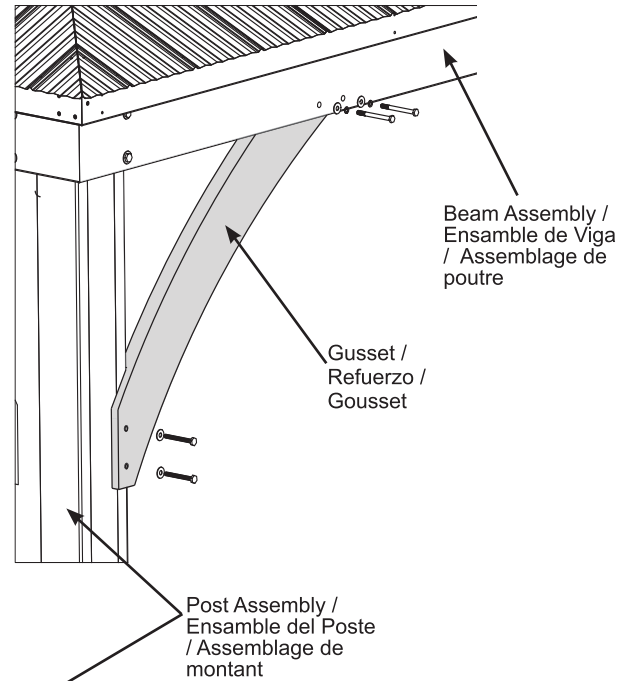
**B:** Sur le même mur, retirez une plinthe avant et une plinthe latérale de chaque Assemblage de montant. (F3.1 et F3.3)

F3.1

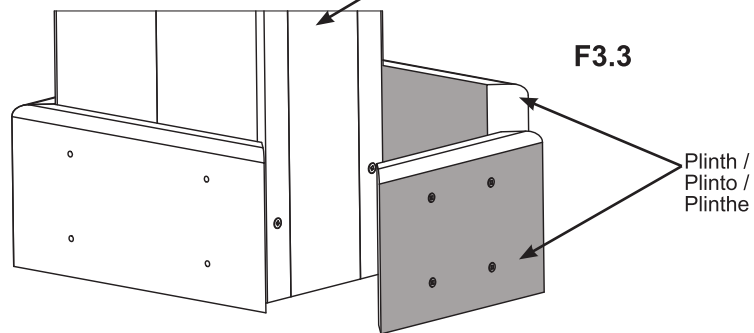


Outside View /  
Vista exterior /  
Vue extérieure

F3.2



F3.3





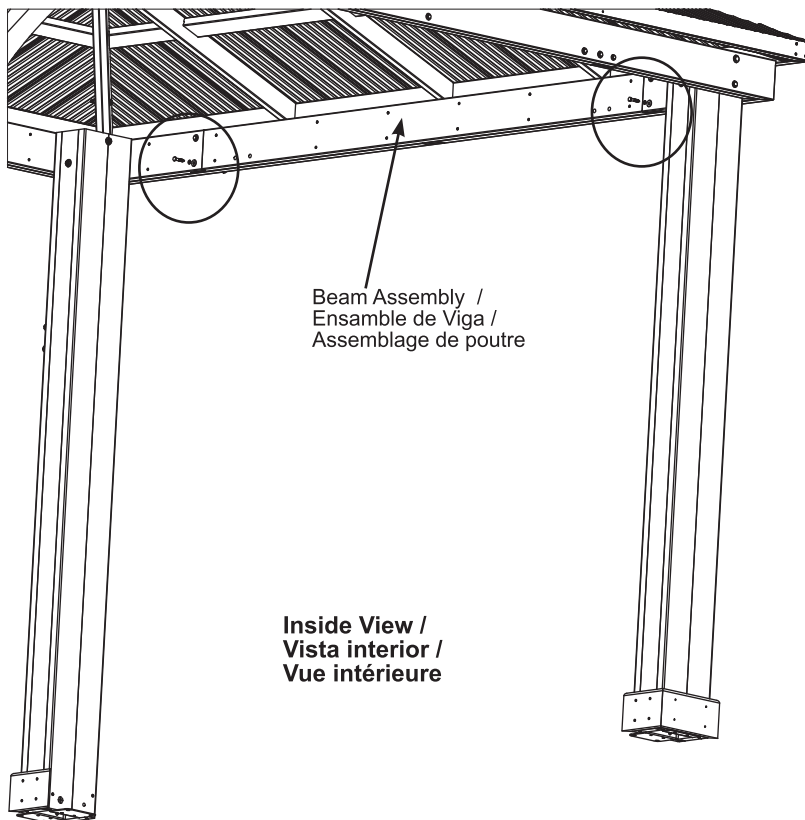
## Step 3: Prepare Gazebo Part 2 - Paso 3: Preparación del Gazebo Parte 2 - Étape 3 : Préparation du gazebo Partie 2

**C:** On the Beam Assembly/  
Short Beam Assembly remove  
the 2 bolts, flat washers and lock  
washers as shown in places below.  
**For the 12 x 16 Gazebo 4 bolts  
will need to be removed.** (F3.4,  
and F3.5)

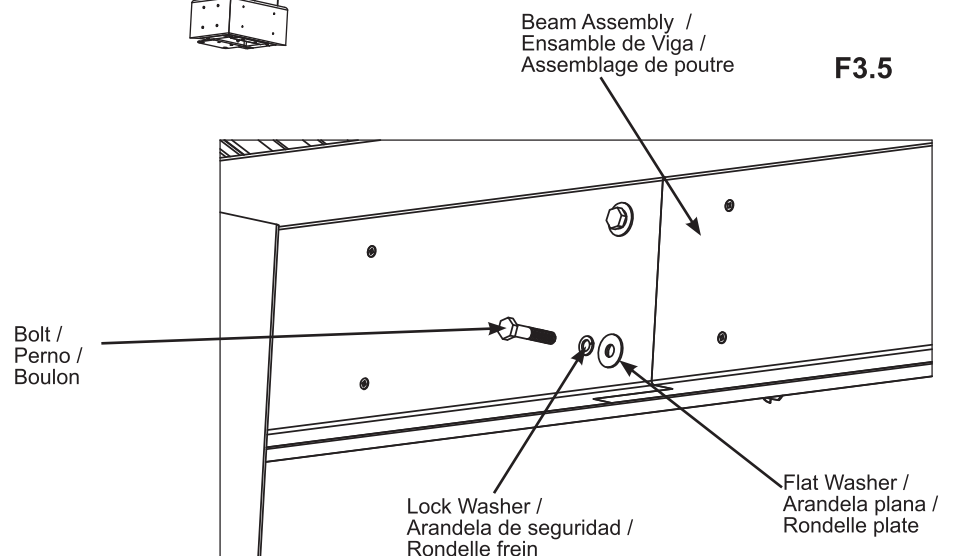
**C:** En el Ensamble de Viga /Viga  
Corta, retire los 2 pernos, arandelas  
planas y arandelas de seguridad  
donde se muestra abajo. **Para  
el Gazebo 12 x 16, los 4 pernos  
deberán quitarse.** (F3.4, y F3.5)

**C:** Sur l'assemblage de poutre/  
l'assemblage de poutre courte,  
retirez les deux boulons, rondelles  
plates et rondelles frein au endroits  
indiqués ci-dessous. **Pour le  
Pavillon 12 x 16, les 4 boulons  
devront être retirés.** (F3.4, et  
F3.5)

F3.4



F3.5



### Step 3: Prepare Gazebo Part 3 - Paso 3: Preparación del Gazebo Parte 3 - Étape 3 : Préparation du gazebo Partie 3

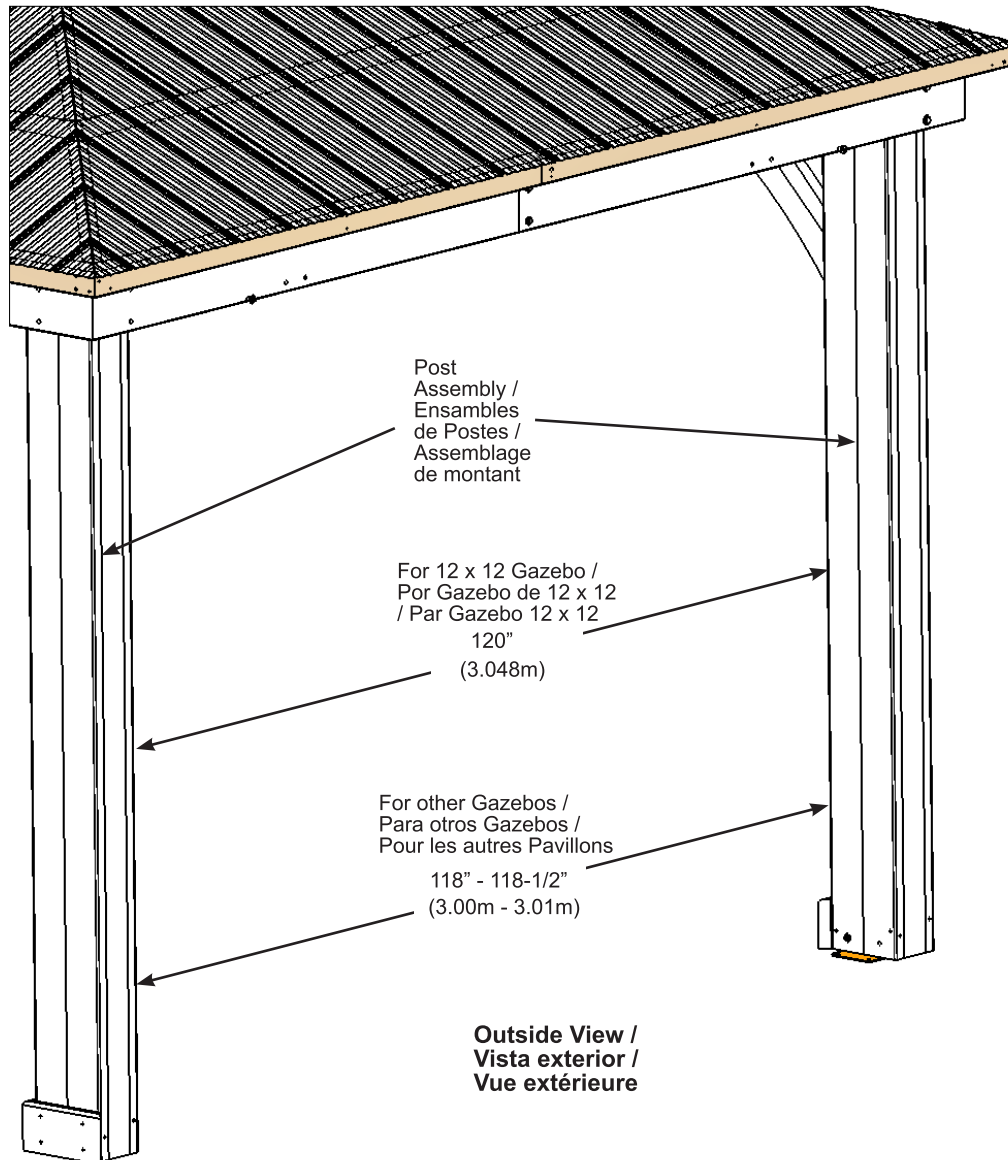


**D:** On the 12 x 12 Gazebo make sure the distance between Post Assemblies is 120" (3.048m). For all other Gazebos the distance should be between 118" (3.00m) and 118-1/2" (3.01m). If not, loosen bolts in posts and beams to get correct measurement. (F3.6)

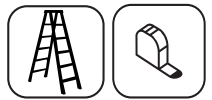
**D:** En el Gazebo 12 x 12, asegúrese de que la distancia entre los Ensamblajes de Postes sea de 120" (3.048m). Para todos los otros Gazebos la distancia debe ser de 118" (3.00m) a 118-1/2" (3.01m). Si no lo es, afloje los pernos de los postes y las vigas hasta obtener la medida correcta. (F3.6)

**D:** Sur le Pavillon 12 x12, assurez-vous que la distance entre les Assemblages de montant est de 120" (3.048m). Pour tous les autres Pavillons, la distance doit être entre 118" (3.00m) et 118-1/2" (3.01m). Si ce n'est pas le cas, desserrez les boulons dans les montants et les poutres pour obtenir la bonne distance. (F3.6)

F3.6



# Step 4: Attach Frame Assemblies Part 1 - Paso 4: Colocación de los marcos Parte 1 - Étape 4 : Fixation des assemblages de cadre Partie 1

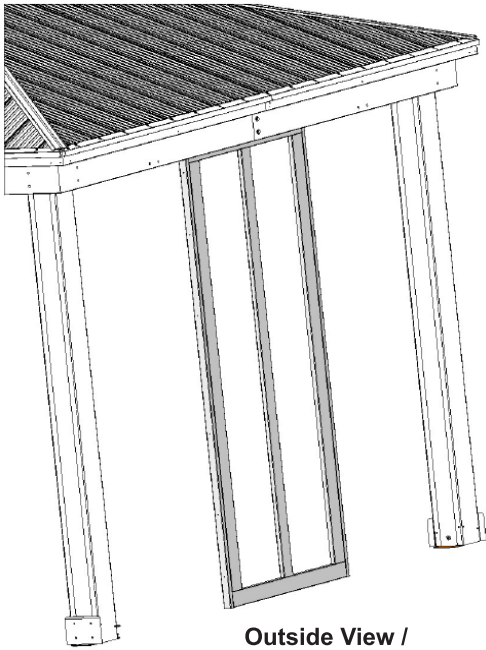


**A:** From inside of the Gazebo place one Frame Assembly equal distance from each Post Assembly. For the 12 x 12 Gazebo use the Frame Assembly with the (1225) Fillers. Attach (1214) Frame Top to beam with four (S3) Wood Screws. (F4.1, F4.2 and F4.3)

**A:** Desde el interior del Gazebo, coloque uno Ensemble del marco a igual distancia de cada Ensemble de Poste. Para el Gazebo 12 x12 usa el ensamble del marco con los Rellenos (1225). Fije la Tabla Superior del Marco (1214) a la viga con cuatro Tornillos para madera (S3). (F4.1, F4.2 y F4.3)

**A:** De l'intérieur du Pavillon, placez l'assemblage de cadre à égale distance de chaque Assemblage de montant. Pour le Pavillon 12 x 12 utilisez l'assemblage de cadre avec les Remplisseurs (1225). Fixez le Dessus de cadre (1214) à la poutre avec quatre Vis à bois (S3). (F4.1, F4.2 et F4.3)

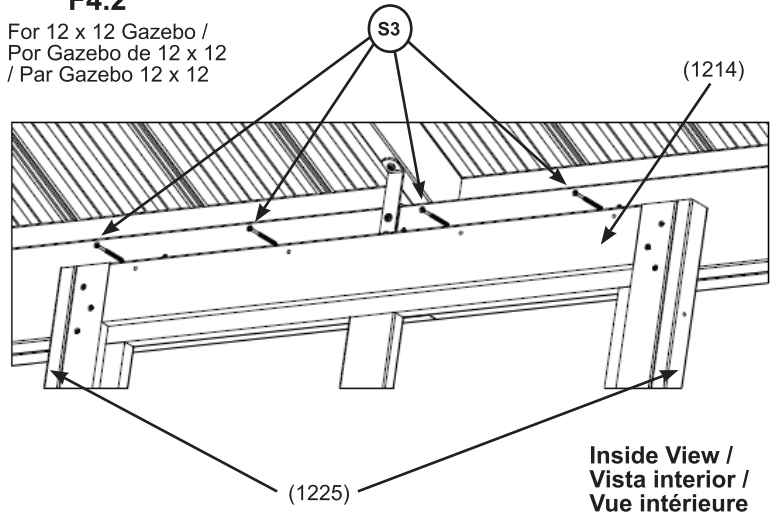
## F4.1



Outside View /  
Vista exterior/  
Vue extérieure

## F4.2

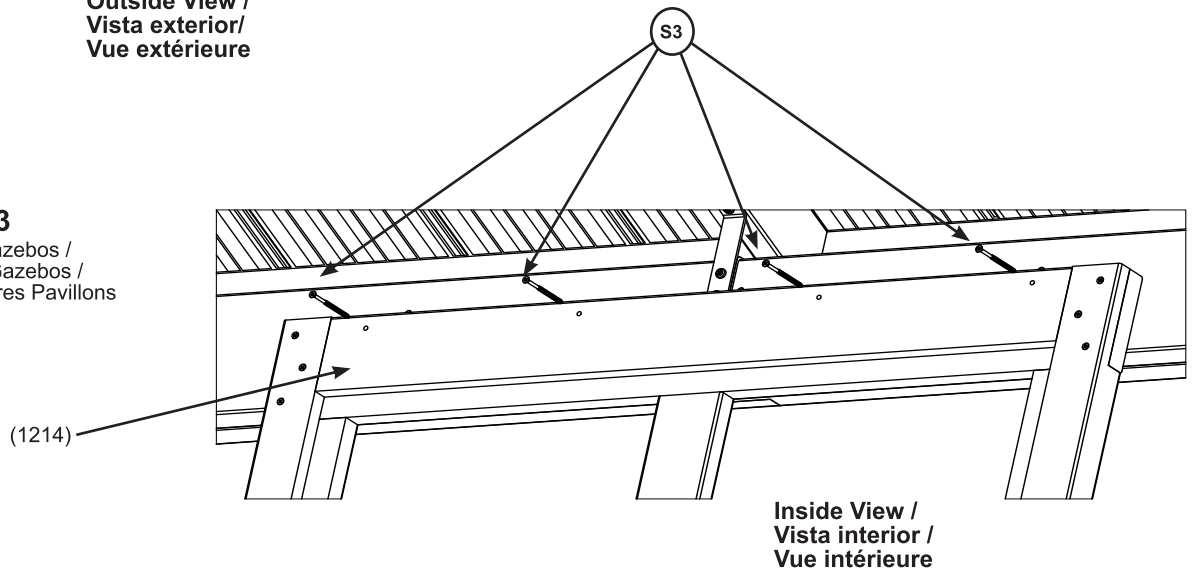
For 12 x 12 Gazebo /  
Por Gazebo de 12 x 12  
/ Par Gazebo 12 x 12



Inside View /  
Vista interior /  
Vue intérieure

## F4.3

For other Gazebos /  
Para otros Gazebos /  
Pour les autres Pavillons



Inside View /  
Vista interior /  
Vue intérieure

### Hardware / Tornillos y accesorios / Quincaillerie

4 x (S3) #8 x 2-1/2"

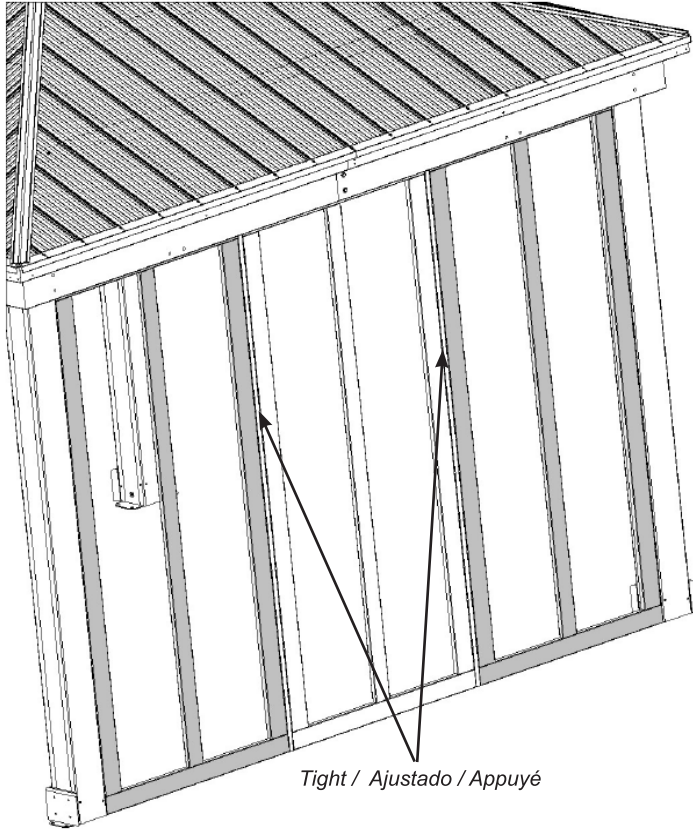
## Step 4: Attach Frame Assemblies Part 2 - Paso 4: Colocación de los marcos Parte 2 - Étape 4 : Fixation des assemblages de cadre Partie 2



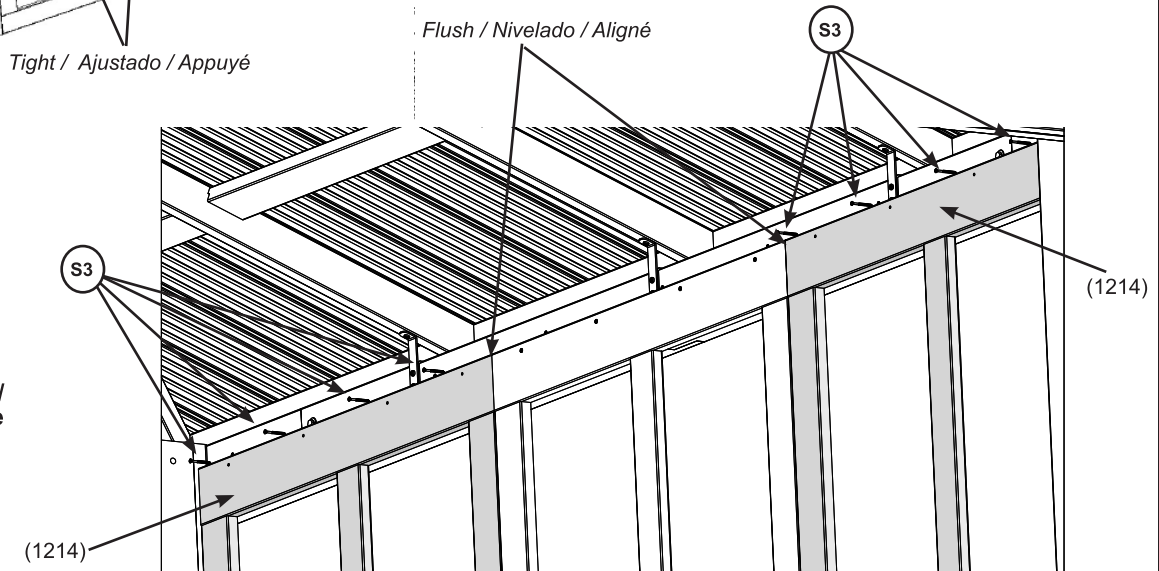
**B:** Tight to first Frame Assembly place other two Frame Assemblies on each side so the tops are flush then attach each (1214) Frame Top to beam with four (S3) Wood Screws per assembly. (F4.3 and F4.4)

**B:** Contra el primer Ensamble del Marco coloque otros dos Ensamblajes de Marcos a cada lado de manera que las puntas queden niveladas y luego fije cada Tabla Superior del Marco (1214) a la viga con cuatro Tornillos para madera (S3) por ensamble. (F4.3 y F4.4)

**B:** Appuyé sur le premier assemblage de cadre, placez deux autres assemblages de cadre de chaque côté de façon à ce que les parties supérieures soient alignées, puis posez chaque Dessus de cadre (1214) à la poutre avec quatre Vis à bois (S3) par assemblage. (F4.3 et F4.4)



**F4.3**  
 Outside View /  
 Vista exterior /  
 Vue extérieure



**F4.4**  
 Inside View /  
 Vista interior /  
 Vue intérieure

### Hardware / Tornillos y accesorios / Quincaillerie

8 x (S3) #8 x 2-1/2"

# Step 5: Attach Ground Supports Part 1 - Paso 5: Colocación de los soportes de la base Parte 1 - Étape 5 : Fixation des supports de sol Partie 1



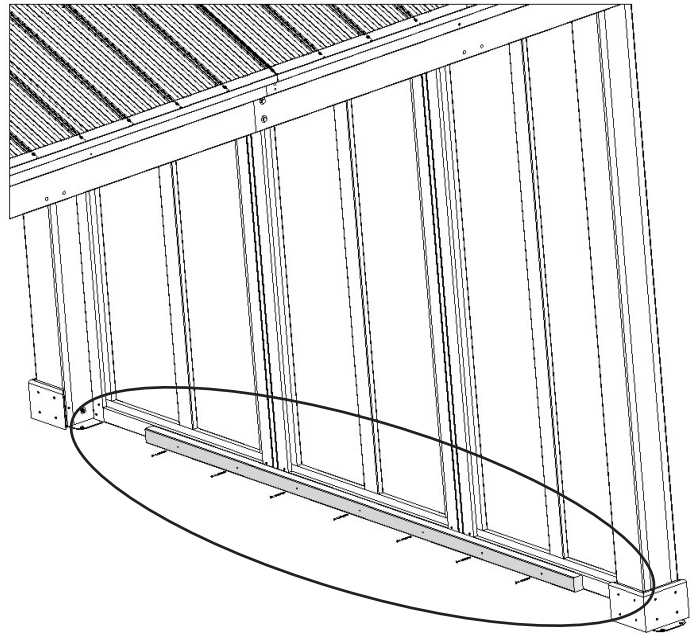
**A:** From inside the assembly place (609) Ground centred at the bottom of the middle Frame Assembly and flush to the bottom then attach to (606) Frame Bottoms with seven (S3) Wood Screws (F5.1 and F5.2)

**A:** Desde el interior del ensamble, coloque la Base (609) centrada sobre la parte inferior del Ensamble del Marco del medio y nivelada con la parte inferior. Luego, fíjela a las Tablas Inferiores del Marco (606) con siete Tornillos para madera (S3). (F5.1 y F5.2)

**A:** De l'intérieur de l'assemblage placez un Sol (609) centré au bas du milieu de l'assemblage de cadre et aligné au bas puis fixez au Bas de cadre (606) avec sept Vis à bois (S3) (F5.1 et F5.2)

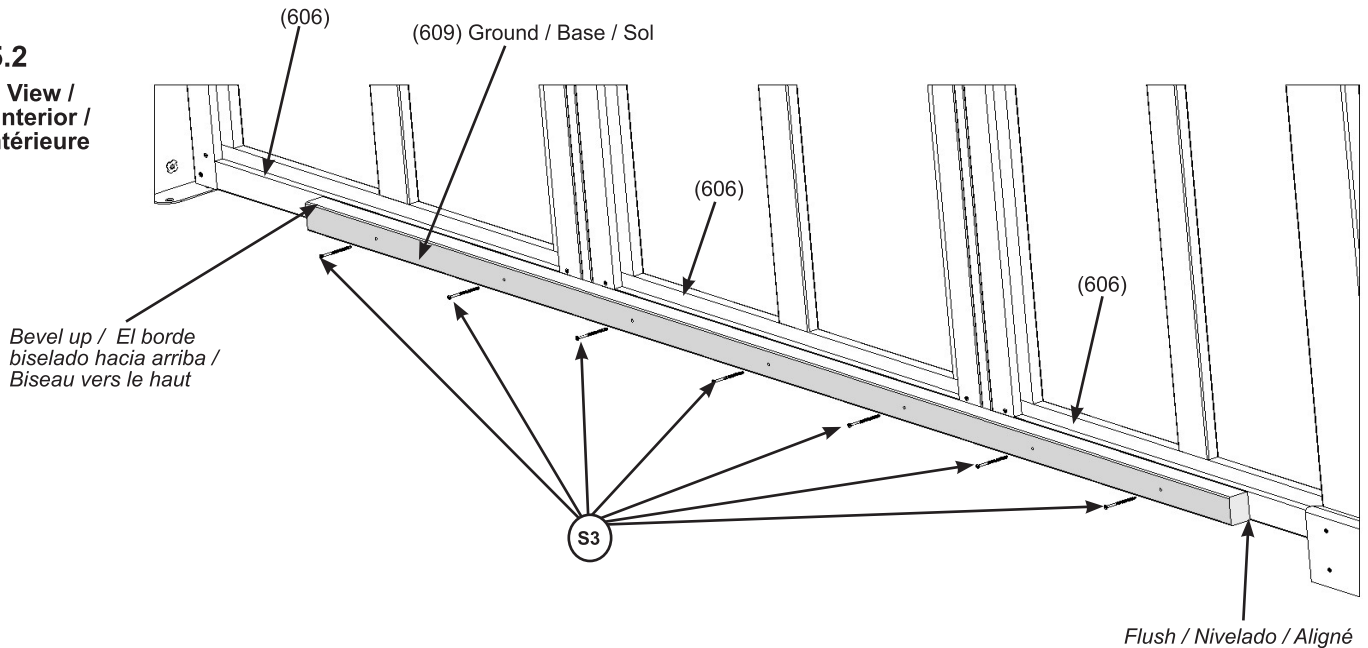
## F5.1

Inside View /  
Vista interior /  
Vue intérieure



## F5.2

Inside View /  
Vista interior /  
Vue intérieure



### Wood / Madera / Bois

1 x (609) Ground / Base / Sol

### Hardware / Tornillos y accesorios / Quincaillerie

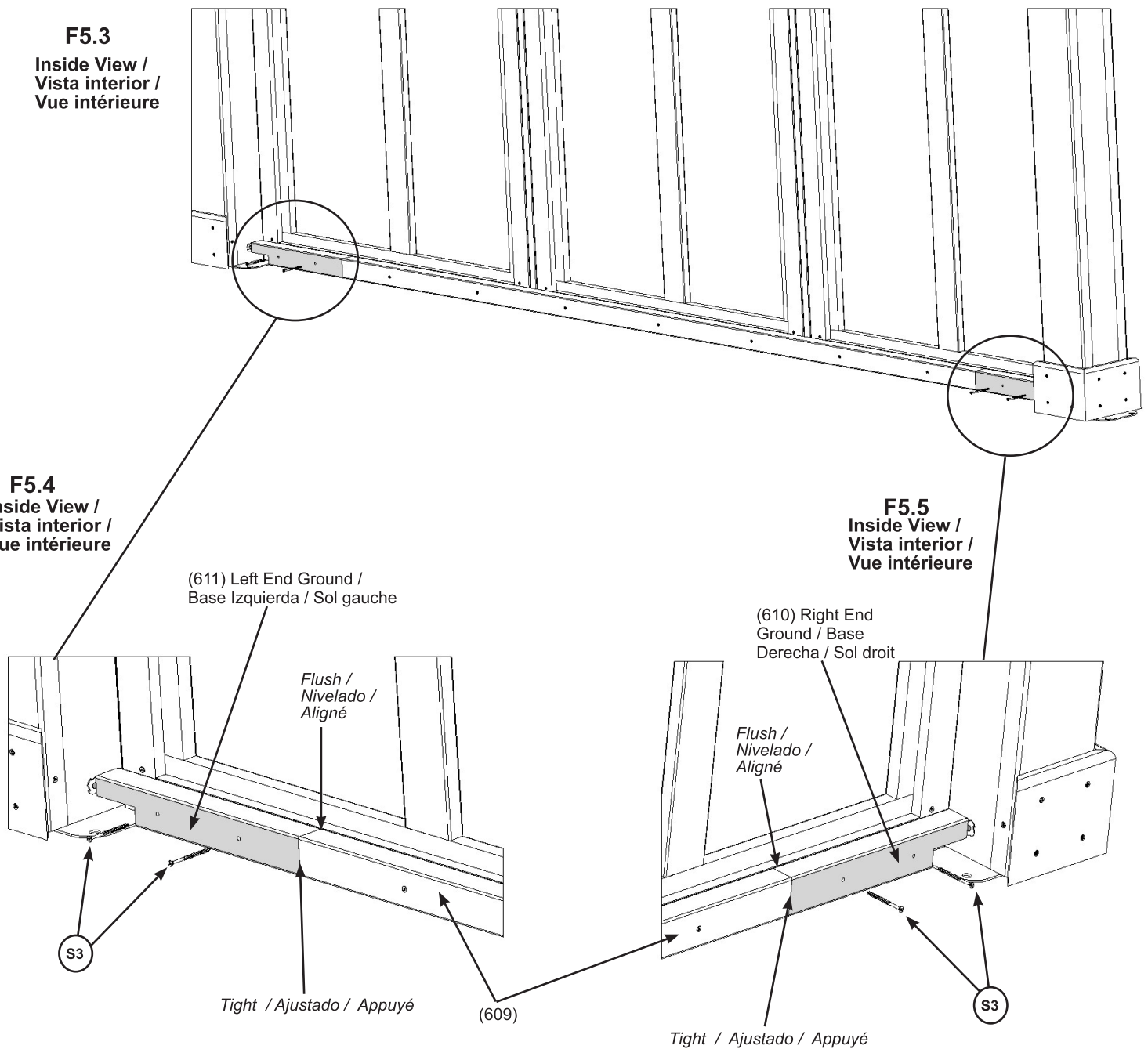
7 x (S3) #8 x 2-1/2"

## Step 5: Attach Ground Supports Part 2 - Paso 5: Colocación de los soportes de la base Parte 2 - Étape 5 : Fixation des supports de sol Partie 2

**B:** Tight to each end and flush to the top of (609) Ground place (610) Right End Ground and (611) Left End Ground then attach with two (S3) Wood Screws per board. (F5.3, F5.4 and F5.5)

**B:** Contra cada extremo y niveladas con la parte superior de la Base (609), coloque la Base Derecha (610) y la Base Izquierda (611) y fijelas con dos Tornillos para madera (S3) por tabla. (F5.3, F5.4 y F5.5)

**B:** Appuyé à chaque extrémité et aligné au haut du Sol (609), placez un Sol droit (610) et un Sol gauche (611) puis fixez avec deux Vis à bois (S3) par planche (F5.3, F5.4 et F5.5)



### Wood / Madera / Bois

- 1 x (610) Right End Ground / Base Derecha / Sol droit
- 1 x (611) Left End Ground / Base Izquierda / Sol gauche

### Hardware / Tornillos y accesorios / Quincaillerie

- 4 x (S3) #8 x 2-1/2"

## Step 6: Attach Outside Plinths - Paso 6: Colocación de los plintos exteriores - Étape 6 : Fixation des plinthes extérieures

**A:** From the outside of the assembly, on the right hand Post Assembly, tight to existing plinth attach (1221) Right Outside Plinth to Post Assembly with four (S15) Wood Screws. (F6.1 and F6.2)

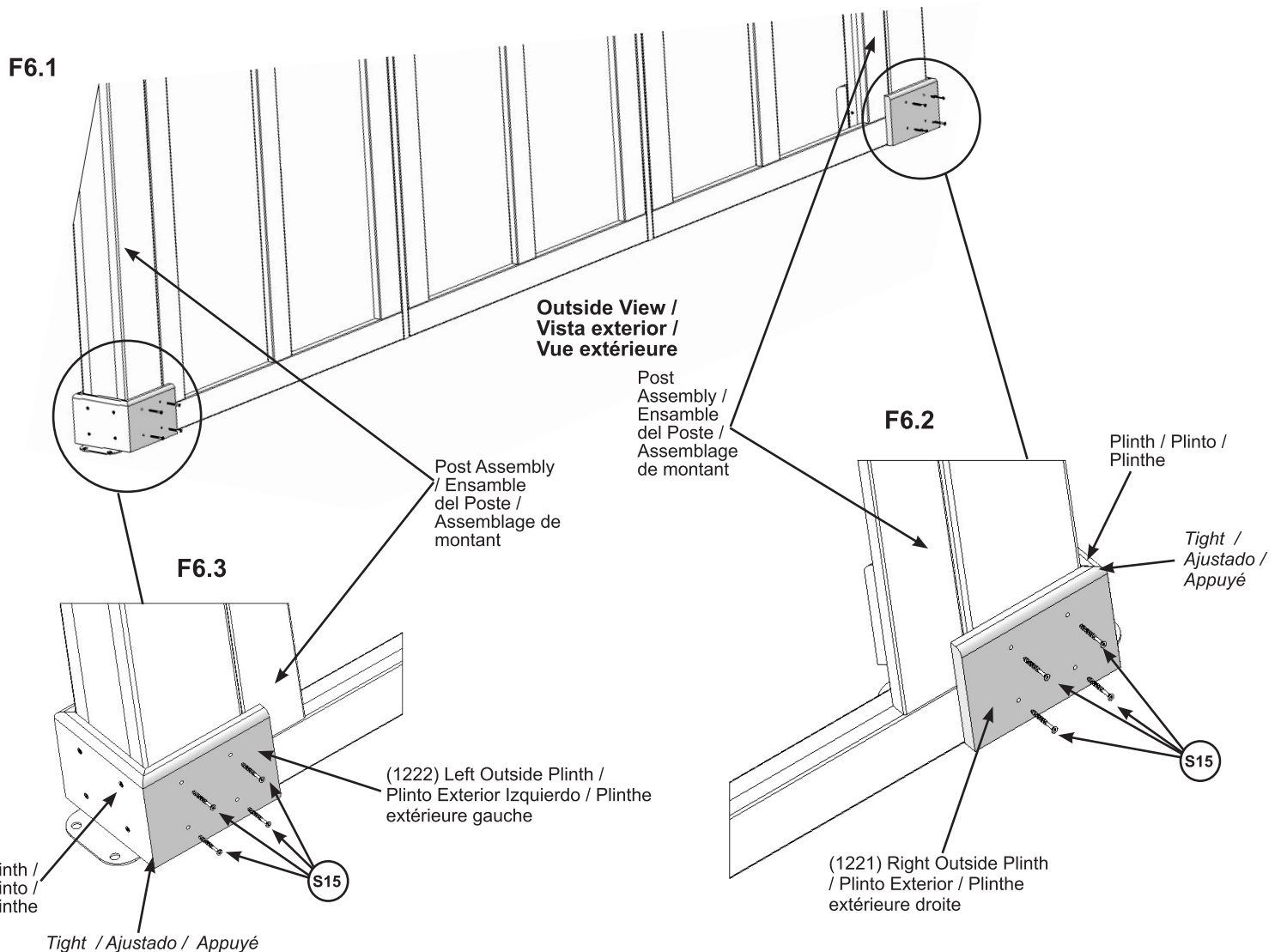
**B:** From the outside of the assembly, on the left hand Post Assembly, tight to existing plinth attach (1222) Left Outside Plinth to Post Assembly with four (S15) Wood Screws. (F6.1 and F6.3)

**A:** Desde el exterior del ensamble, en el Ensamble del Poste del lado derecho y contra el plinto ya colocado, fije el Plinto Exterior Derecho (1221) al Ensamble del Poste con cuatro Tornillos para madera (S15). (F6.1 y F6.2)

**B:** Desde el exterior del ensamble, en el Ensamble del Poste del lado izquierdo y contra el plinto ya colocado, fije el Plinto Exterior Izquierdo (1222) al Ensamble del Poste con cuatro Tornillos para madera (S15). (F6.1 y F6.3)

**A:** De l'extérieur de l'assemblage, du côté droit de l'assemblage de montant, appuyé à la plinthe existante, fixez la Plinthe extérieure droite (1221) à l'assemblage de montant avec quatre Vis à bois (S15). (F6.1 et F6.2)

**B:** De l'extérieur de l'assemblage, du côté gauche de l'assemblage de montant, appuyé à la plinthe existante, fixez la Plinthe extérieure gauche (1222) à l'assemblage de montant avec quatre Vis à bois (S15). (F6.1 et F6.3)



### Wood / Madera / Bois

- 1 x (1221) Right Outside Plinth / Plinto Exterior Derecho / Plinthe extérieure droite
- 1 x (1222) Left Outside Plinth / Plinto Exterior Izquierdo / Plinthe extérieure gauche

### Hardware / Tornillos y accesorios / Quincaillerie

- 8 x (S15) #8 x 1-3/4"

## Step 7: Attach Post Supports - Paso 7: Fijación de los soportes de los postes - Étape 7 : Fixation des supports de montant

**A:** From inside the assembly, tight to one Post Assembly place one (1220) Post Support, make sure the top of the support has the notch facing out then attach to Frame Assembly with four (S3) Wood Screws then to Post Assembly with five (S24) Wood Screws. (F7.1, F7.2 and F7.3)

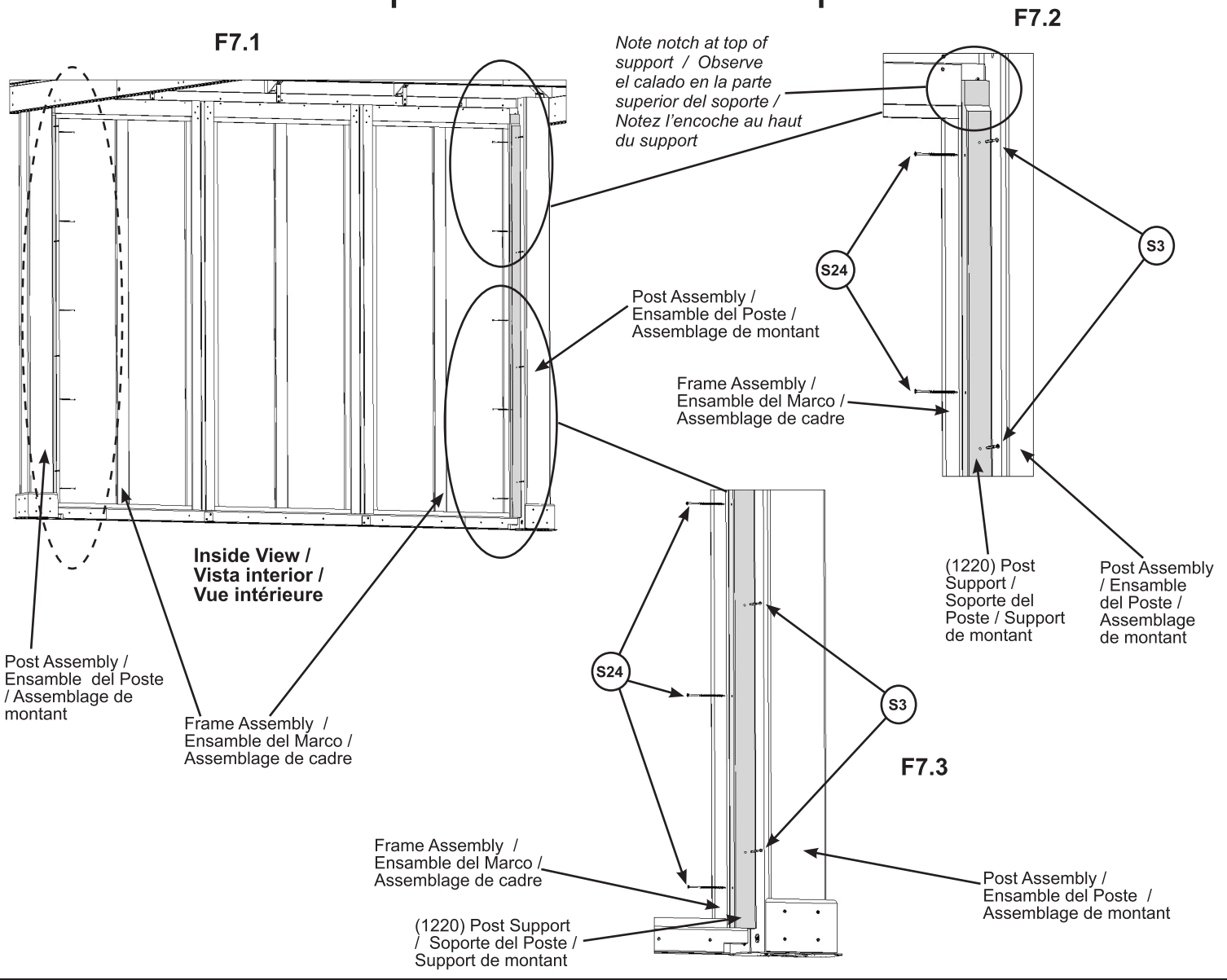
**B:** Repeat A for opposite Post Assembly.

**A:** Desde el interior del ensamble, contra uno de los Ensamblados de Postes, coloque un Soporte del Poste (1220) asegurándose de que la parte superior del soporte tenga el calado hacia afuera. Luego, fíjelo al Ensamble del Marco con cuatro Tornillos para madera (S3) y al Ensamble del Poste con cinco Tornillos para madera (S24) (F7.1, F7.2 y F7.3)

**B:** Repita el Paso A en el otro Ensamble del Poste.

**A:** De l'intérieur de l'assemblage, appuyé sur un assemblage de montant placez un Support de montant (1220), assurez-vous que l'encoche au haut du support est face vers l'extérieur, puis fixez à l'assemblage de cadre avec quatre Vis à bois (S3) puis à l'assemblage de montant avec cinq Vis à bois (S24). (F7.1, F7.2 et F7.3)

**B:** Répétez l'étape A pour l'assemblage de montant opposé.




### Wood / Madera / Bois

2 x (1220) Post Support / Soporte del Poste / Support de montant

### Hardware / Tornillos y accesorios / Quincaillerie

8 x  #8 x 2-1/2"

10 x  #10 x 4"



## Step 8: Attach Panels - Paso 8: Fijación de los paneles - Étape 8 : Fixation des panneaux

**A:** From inside the assembly attach one (599) Louvered Panel Assembly to the bottom of one Frame Assembly with nine (S15) Wood Screws. Screws attach to (1216) Post Left, (1217) Post Right and (602) Frame Centre Dowel Assembly. (F8.1 and F8.2)

**B:** Tight to the top of the first (599) Louvered Panel Assembly attach three more (599) Louvered Panel Assemblies with nine (S15) Wood Screws per panel. (F8.1 and F8.2)

**C:** Repeat A and B for two remaining Frame Assemblies.

**A:** Desde el interior del ensamble, Fije un Ensamble del Panel Apersianado (599) a la parte inferior de un Ensamble del Marco con nueve Tornillos para madera (S15). Los tornillos se fijan al Poste Izquierdo (1216), al Poste Derecho (1217) y al Ensamble de la Tabla Central del Marco (602). (F8.1 y F8.2)

**B:** Contra la parte superior del primer Ensamble del Panel Apersianado (599), fije tres Ensamblados de Paneles Apersianados (599) más con nueve Tornillos para madera (S15) por panel. (F8.1 y F8.2)

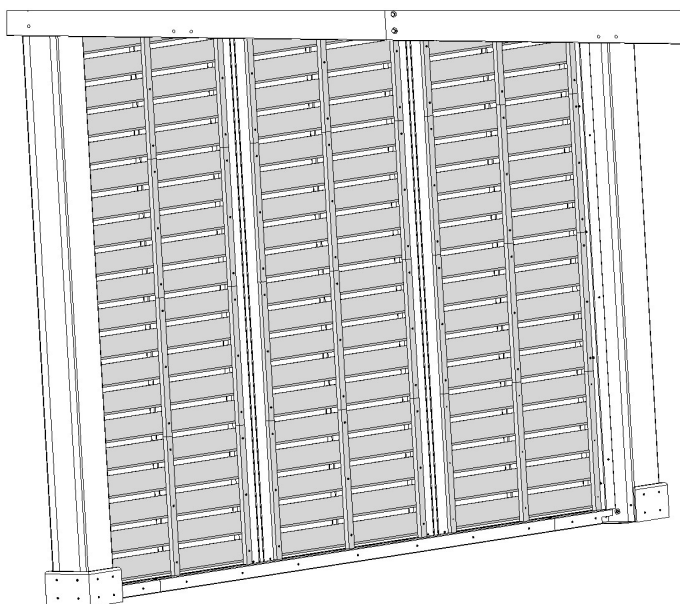
**C:** Repita el Paso A y B para los dos Ensamblados de Marcos restantes.

**A:** De l'intérieur de l'assemblage, fixez un Assemblage de panneau de persienne (599) au bas d'un assemblage de cadre avec neuf Vis à bois (S15). Les vis se fixent au Montant gauche (1216), au Montant droit (1217) et à l'assemblage de goujon central de cadre (602). (F8.1 et F8.2)

**B:** Appuyé au haut du premier Assemblage de panneau de persienne (599), fixez trois autres Assemblages de panneau de persienne (599) avec neuf Vis à bois (S15) par panneau. (F8.1 et F8.2)

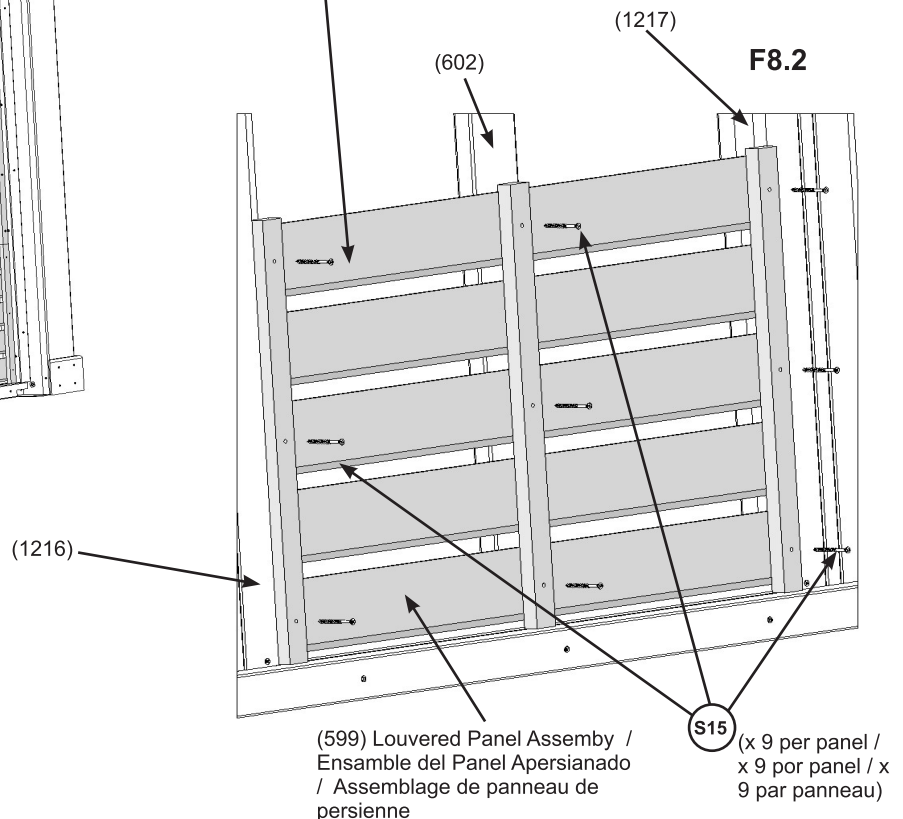
**C:** Répétez les étapes A et B pour créer les deux assemblages de cadre restants.

F8.1



Inside View /  
Vista interior /  
Vue intérieure

Notice orientation of slats and make identical for each panel. / Observe la orientación de las tablillas y haga todos los paneles idénticos. / Notez l'orientation des lattes et assurez-vous qu'elle est identique pour chaque panneau.



(599) Louvered Panel Assembly /  
Ensamble del Panel Apersianado  
/ Assemblage de panneau de  
persienne

(S15) (x 9 per panel /  
x 9 por panel / x  
9 par panneau)

### Wood / Madera / Bois

12 x (599) Louvered Panel Assembly / Ensamble del Panel Apersianado /  
Assemblage de panneau de persienne

### Hardware / Tornillos y accesorios / Quincaillerie

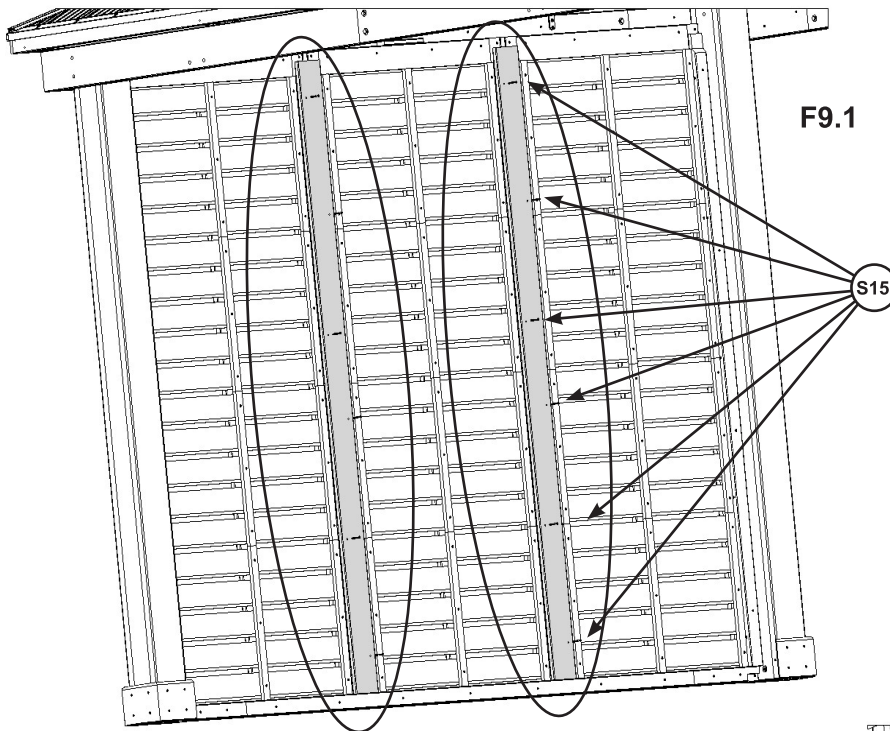
108 x (S15) #8 x 1-3/4"

## Step 9: Attach Middle Supports - Paso 9: Fijación de los soportes medios - Étape 9 : Fixation des supports centraux

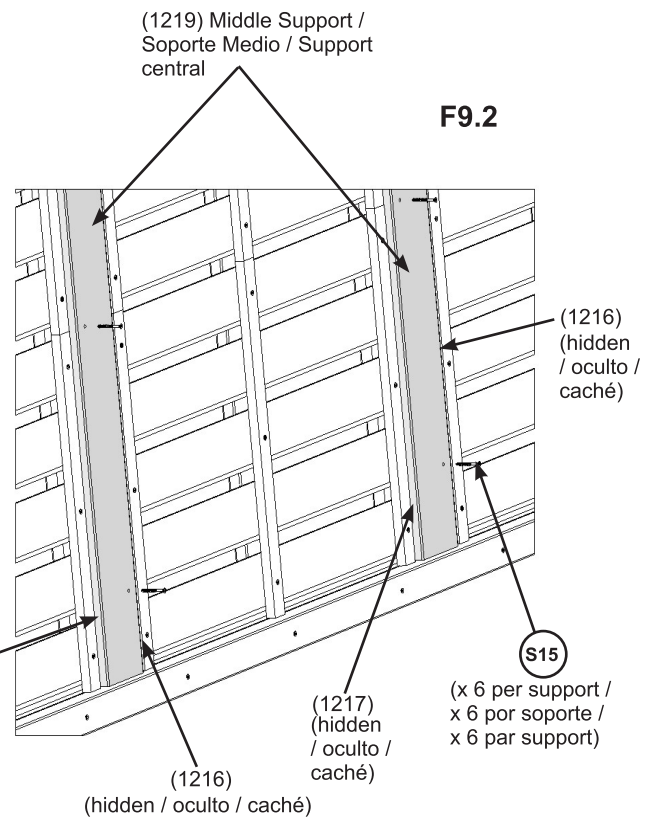
**A:** From inside the assembly place one (1219) Middle Support over each middle (1216) Post Left and (1217) Post Right connection and attach with six (S15) Wood Screw per support. (F9.1 and F9.2)

**A:** Desde el interior del ensamble, coloque un Soporte Medio (1219) sobre cada unión del Poste Izquierdo (1216) y Poste Derecho (1217) y fíjelo con seis Tornillos para madera (S15) por soporte. (F9.1 y F9.2)

**A:** De l'intérieur de l'assemblage, placez un Support central (1219) au-dessus de chaque Montant gauche central (1216) et connexion de Montant droit (1217) et fixez avec six Vis à bois (S15) par support. (F9.1 et F9.2)



Inside View /  
Vista Interior /  
Vue intérieure



### Wood / Madera / Bois

2 x (1219) Middle Support / Soporte Medio / Support central

### Hardware / Tornillos y accesorios / Quincaillerie

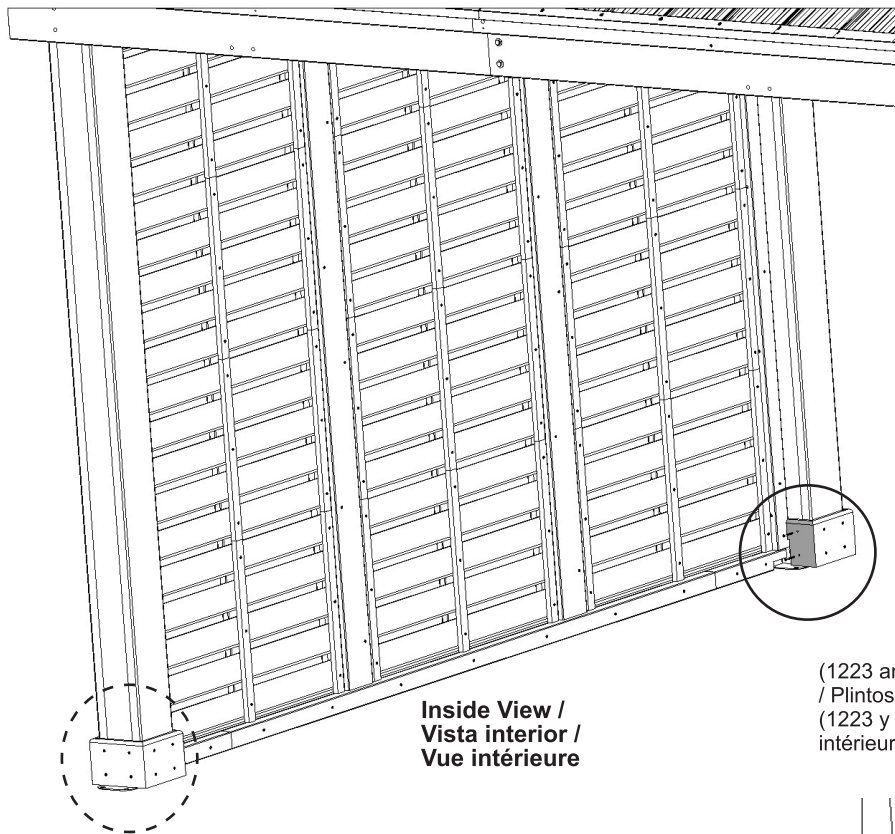
12 x (S15) #8 x 1-3/4"

# Step 10: Attach Inside Plinths - Paso 10: Fijación de los plintos interiores - Étape 10 : Fixation des plinthes intérieures

**A:** From the inside of the assembly attach (1224) Inside Right Plinth to right Post Assembly with two (S15) Wood Screws. Repeat on the left hand Post Assembly with (1223) Inside Left Plinth. (F10.1 and F10.2)

**A:** Desde el interior del ensamble, fije el Plinto Interior Derecho (1224) al Ensamble del Poste Derecho con dos Tornillos para madera (S15). Repítalo en el Ensamble del Poste izquierdo con el Plinto Interior Izquierdo (1223). (F10.1 y F10.2)

**A:** De l'intérieur de l'assemblage, fixez la Plinthe droite intérieure (1224) à l'assemblage de montant droit avec deux Vis à bois (S15). Répétez sur l'assemblage de montant gauche avec la Plinthe gauche intérieure (1223). (F10.1 et F10.2)



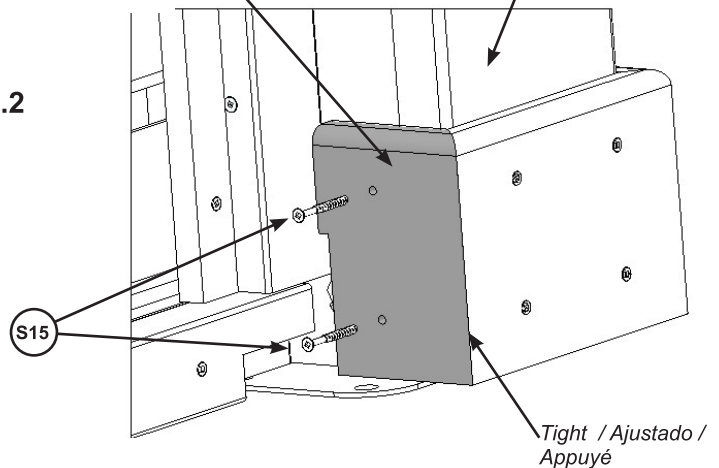
**F10.1**

**Inside View /  
Vista interior /  
Vue intérieure**

(1223 and 1224) Inside Plinths /  
Plintos Ajustado Interiores  
(1223 y 1224) / Plinthes  
intérieures (1223 et 1224)

Post Assembly /  
Ensamble del Poste /  
Assemblage de montant

**F10.2**



## Wood / Madera / Bois

- 1 x (1223) Inside Left Plinth / Plinto Interior Izquierdo / Plinthe gauche intérieure
- 1 x (1224) Inside Right Plinth / Plinto Interior Derecho / Plinthe gauche intérieure

## Hardware / Tornillos y accesorios / Quincaillerie

- 4 x (S15) #8 x 1-3/4"

## Step 11: Attach Corner Brackets - Paso 11: Fijación de los soportes de esquina - Étape 11 : Fixation des équerres de coin

**A:** From inside the assembly place two Corner Brackets flush to bottom of (609) Ground and centred under each (1219) Middle Support and attach with two (S12) Pan Screws per bracket. F11.1 and F11.2)

**B:** Fasten Corner Brackets to ground surface using appropriate hardware for surface material.

**Note:** Anchoring hardware is not included.

**A:** Desde el interior del ensamble, coloque dos Soportes de Esquina nivelados con la parte inferior de la Base (609) y centrados debajo de cada Soporte Medio (1219) y fíjelos con dos Tornillos de cabeza plana (S12) por soporte. (F11.1 y F11.2)

**B:** Fije los Soportes de Esquina a la superficie del piso usando los accesorios adecuados para el material del piso.

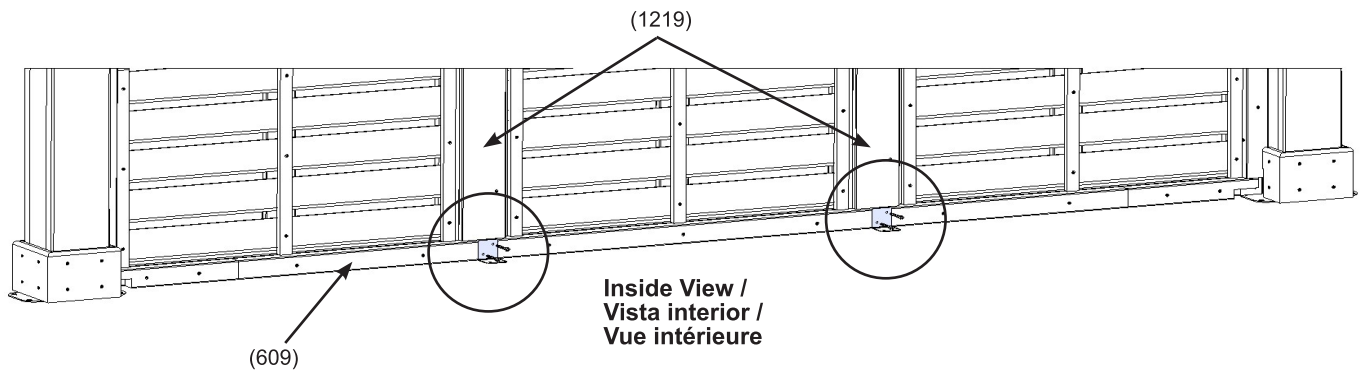
**Nota:** Los tornillos de anclaje no vienen incluidos.

**A:** De l'intérieur de l'assemblage, placez deux équerres de coin alignées au bas du Sol (609) et centrées sous chaque Support central (1219) et fixez avec deux Vis à tête cylindrique (S12) par équerre. F11.1 et F11.2)

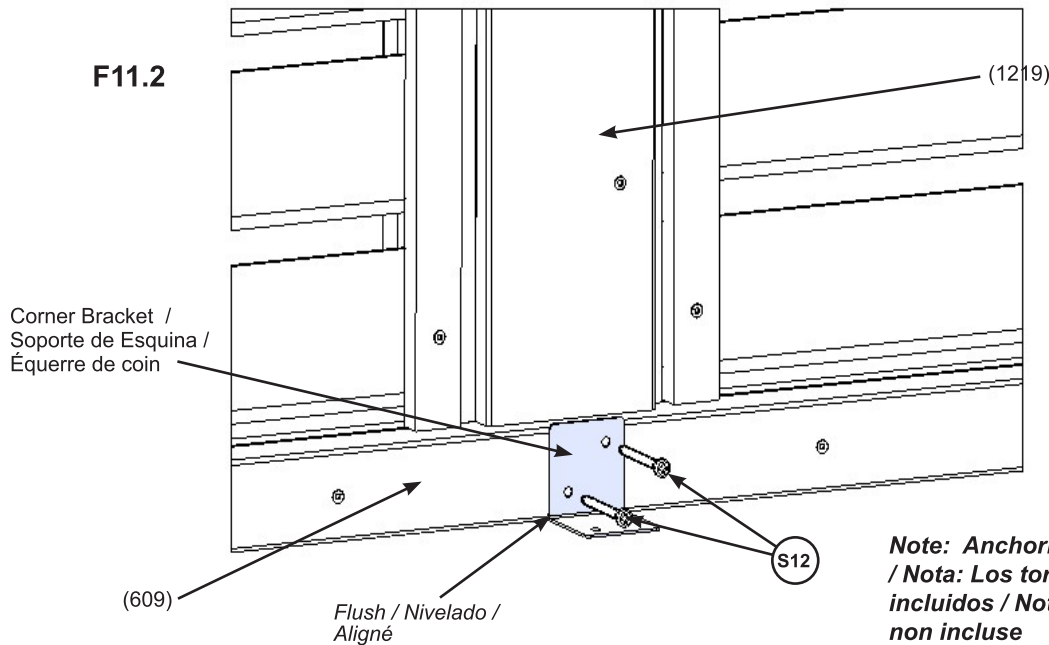
**B:** Fixez les équerres de coin à la surface du sol à l'aide de la quincaillerie appropriée au matériau de surface.

**Note:** La quincaillerie d'ancrage n'est pas incluse.

F11.1



F11.2



**Note: Anchoring Hardware not included / Nota: Los tornillos de anclaje no vienen incluidos / Note: Quincaillerie d'ancrage non incluse**

### Hardware / Tornillos y accesorios / Quincaillerie

4 x (S12) #10 x 1-1/4"

2 x Corner Bracket / Soporte de Esquina / Équerre de coin

## Limited Warranty - Garantía Limitada - Garantie limitée

Yardistry warrants that this product is free from defect in materials and workmanship for a period of one (1) year from the original date of purchase. In addition, for any product with lumber, all lumber is warranted for five (5) years against rot and decay. This warranty applies to the original owner and registrant and is non-transferable.

Regular maintenance is required to assure the integrity of your product and is a requirement of the warranty. This warranty does not cover any inspection costs.

### **This Limited Warranty does not cover:**

- Labour for replacement of any defective item(s);
- Incidental or consequential damages;
- Cosmetic defects which do not affect performance or integrity;
- Vandalism; improper use or installation; acts of nature, including but not limited to wind, storms, hail, floods, excessive water exposure;
- Minor twisting, warping, checking or any other natural occurring properties of wood that do not affect performance or integrity.

Yardistry products have been designed for safety and quality. Any modifications made to the original product could damage the structural integrity of the product leading to failure and possible injury. Yardistry cannot assume any responsibility for modified products. Furthermore, modification voids any and all warranties.

**This product is warranted for RESIDENTIAL USE ONLY. Yardistry disclaims all other representations and warranties of any kind, express or implied.**

*This Warranty gives you specific legal rights. You may have other rights as well which vary from state to state or province to province. This warranty excludes all consequential damages, however, some states/provinces do not allow the limitation or exclusion of consequential damages, and therefore this limitation may not apply to you.*

Yardistry garantiza que este producto está libre de defectos en materiales y mano de obra por un período de un (1) año de la fecha original de compra. Adicionalmente, para cualquier product con madera, toda la madera está garantizada por cinco (5) años contra la degradación y putrefacción. Esta garantía aplica al dueño original y registrante y no es transferible.

Se requiere mantenimiento regular para asegurar la integridad de su producto y es un requisito de la garantía. Esta garantía no cubre cualquier costo de inspección..

### **Esta Garantía Limitada no cubre:**

- Trabajo para el reemplazo de cualquier artículo(s) defectuoso;
- Daños incidentales o consecuentes;
- Defectos cosméticos que no afecten el rendimiento o la integridad;
- Vandalismo, uso o instalación inapropiados, actos de la naturaleza incluyendo pero no limitándose a los vientos, tormentas, granizo, inundaciones, exceso de exposición al agua;
- Menor torsión, deformación, agrietado, o cualquier otra propiedad natural concurrente a la madera que no afecte su rendimiento o integridad.

Los productos Yardistry han sido diseñados para seguridad y calidad. Cualquier modificaciones hechas al producto original pueden dañar la integridad estructural del producto, provocando fallas o posibles lesiones. Yardistry no puede asumir ninguna responsabilidad para productos modificados. Además, las modificaciones anulan cualquiera y todas las garantías.

**Este producto está garantizado para USO RESIDENCIAL SOLAMENTE. Yardistry renuncia a todas las representaciones y garantías de todo tipo, expresas o implícitas.**

*Esta Garantía le brinda derechos legales específicos. Puede tener otros derechos también que varían de estado a estado o provincia a provincia. Esta garantía excluye todos los daños consecuentes, sin embargo, algunos estados no permiten la limitación or exclusión de daños consecuentes, y por lo tanto esta limitación no se aplica con usted.*

Yardistry garantit que ce produit est exempt de défauts de fabrication ou de conception pendant une période d'un (1) an suivant la date d'achat. De plus, pour tout produit avec du bois, tout le bois est garanti pendant cinq (5) ans contre la dégradation et la pourriture. Cette garantie s'applique à l'acheteur original, et n'est pas transférable.

Un entretien régulier est requis afin d'assurer l'intégrité de votre produit, et constitue une exigence pour cette garantie. Cette garantie ne couvre aucun coût d'inspection.

### **Cette garantie limitée ne couvre pas:**

- Main d'oeuvre pour le remplacement de tout élément défectueux;
- Dommages indirects ou consécutifs;
- Défauts esthétiques n'affectant pas la performance ou l'intégrité;
- Vandalisme; installation ou usage inadéquat; actes de la nature incluant, sans s'y limiter, le vent, les tempêtes, la grêle, les inondations ou une exposition excessive à l'eau;
- Faible torsion, déformation ou fendillement, ou toute autre transformation naturelle du bois n'affectant pas la performance ou l'intégrité.

Les produits Yardistry ont été conçus dans une optique de qualité et de sécurité. Toute modification effectuée au produit original pourrait endommager l'intégrité structurelle du produit, entraînant des défaillances et potentiellement des blessures. Yardistry ne peut assumer aucune responsabilité pour les produits ayant été modifiés. De plus, toute modification annule toutes les garanties, quelles qu'elles soient.

**Ce produit est garanti pour un USAGE RÉSIDENCIEL SEULEMENT. Yardistry décline toute autre déclaration ou garantie, expresse ou implicite.**

*Cette garantie vous octroie des droits légaux spécifiques. Vous pourriez bénéficier d'autres droits, qui varient selon l'état ou la province ou vous résidez. Cette garantie exclut tous les dommages indirects, toutefois, certains états ne permettent pas la restriction ou l'exclusion des dommages indirects, alors cette restriction pourrait ne pas s'appliquer à votre situation.*



# NOTES

---

---

---

---

---

---

---

---

---

---

---

---

---

---

---

---

---

---

---

---

---

---

---

---

---

---

---



## Customer Registration Card - Tarjeta de Registro del Cliente - Carte d'inscription du client

First Name - Primer Nombre - Prénom	Initial - Inicial - Initiale	Last Name - Apellido - Nom de famille

Street - Calle - Rue	PO Box - Casilla postal - Boîte postale	Apt. No. - App.

City - Ciudad - Ville	State/Province - Estado/Provincia - État/Province

ZIP/Postal Code - Código Postal - ZIP/Code postal	Country - País - Pays

E-mail Address - Dirección de E-mail - Adresse courriel	Telephone Number - No. de Teléfono - N° de téléphone

Model Name - Nombre del Modelo - Nom du modèle	Model Number (from front cover) - Número de Modelo (de la portada) - N° du modèle (page de couverture)

Date of Purchase - Fecha de Compra - Date d'achat (mm/dd/yyyy) (mm/dd/aaaa) (mm/jj/aaaa)	Place of Purchase - Comprado a - Lieu d'achat

Comments - Comentarios - Commentaires:

### Mail To - Enviar por Correo a - Envoyer par courrier à:

Yardistry  
375 Sligo Road West, PO Box 10  
Mount Forest, Ontario, Canada, N0G 2L0  
Attention: Consumer Relations  
Atención a: Servicio de Atención al Cliente  
À l'attention de: Service à la clientèle

### Online Registration - Registro online - Enregistrement en ligne:

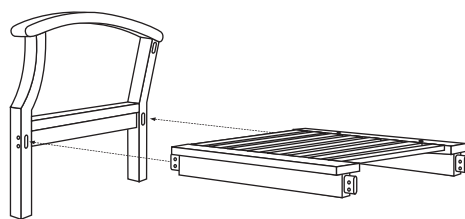
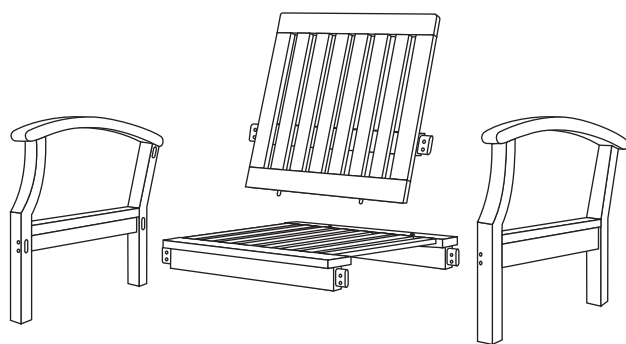
[www.yardistrystructures.com/warranty](http://www.yardistrystructures.com/warranty)

Yardistry would like to say "Thank you" for your time and feedback.  
Yardistry quiere "Agradecerle" por su tiempo y su opinión.  
Yardistry aimerait vous remercier d'avoir pris le temps de répondre au sondage.

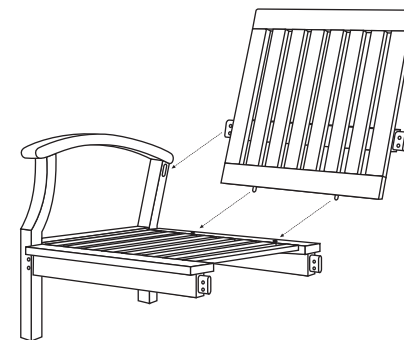


# Manual Instruction For Sevilla Club Chair

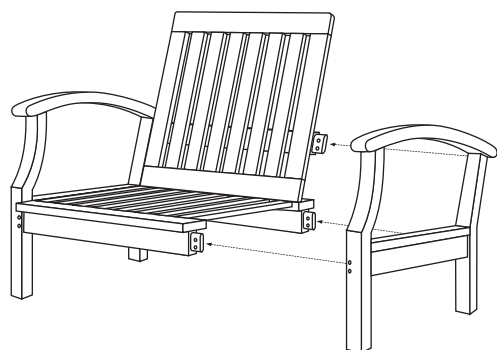
## The Component For Sevilla Club Chair



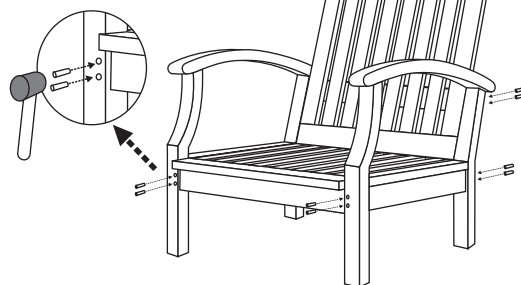
Step 1 : Please install the seat of bench to one of leg



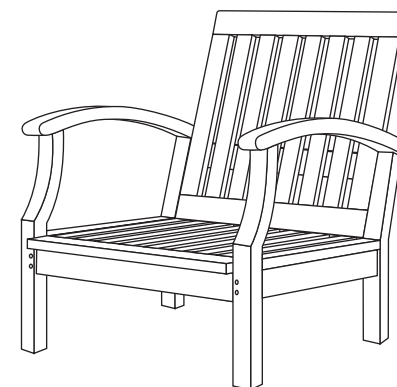
Step 2 : Please install the back of bench to step 1



Step 3 : Please install the other leg to step 2

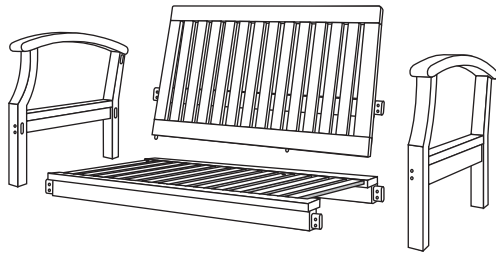


Step 4 : Please instal the dowels to hole that available.

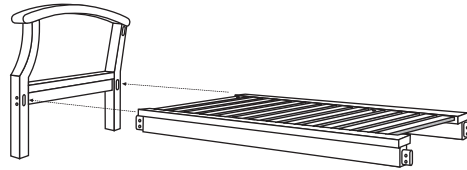


# Manual Instruction For Sevilla Love Seat

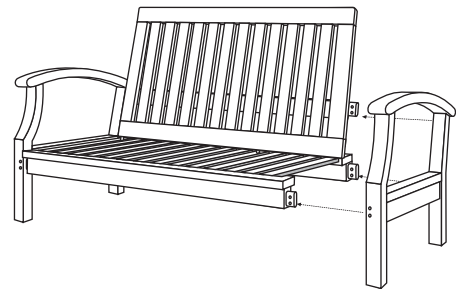
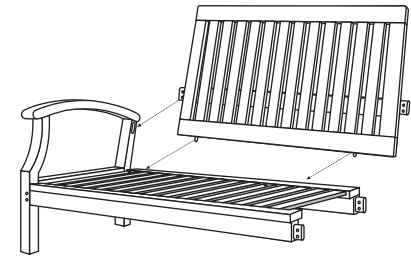
The Component For Sevilla Love Seat



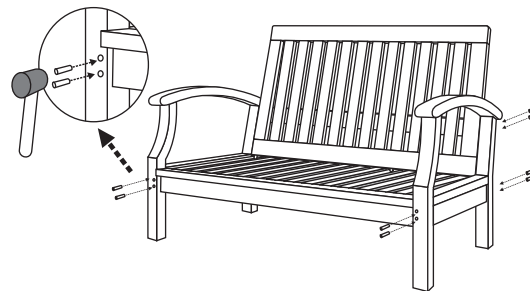
Step 1 : Please install the seat of bench to one of leg of bench



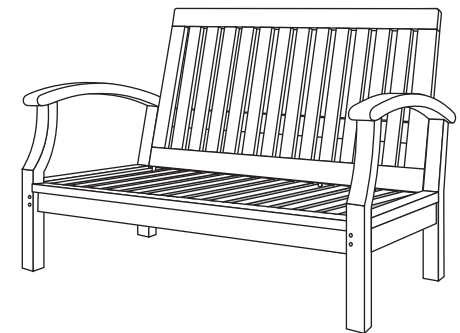
Step 2 : Please install the back of bench to step 1

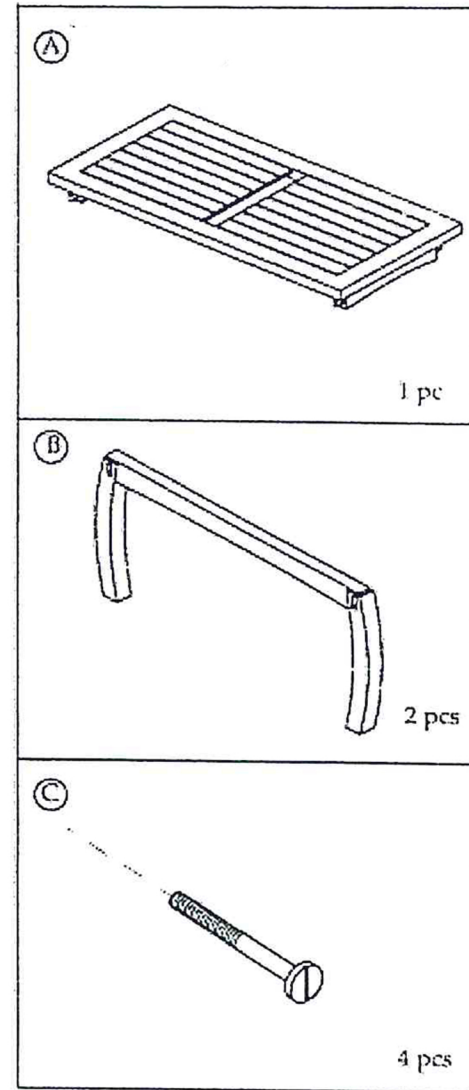
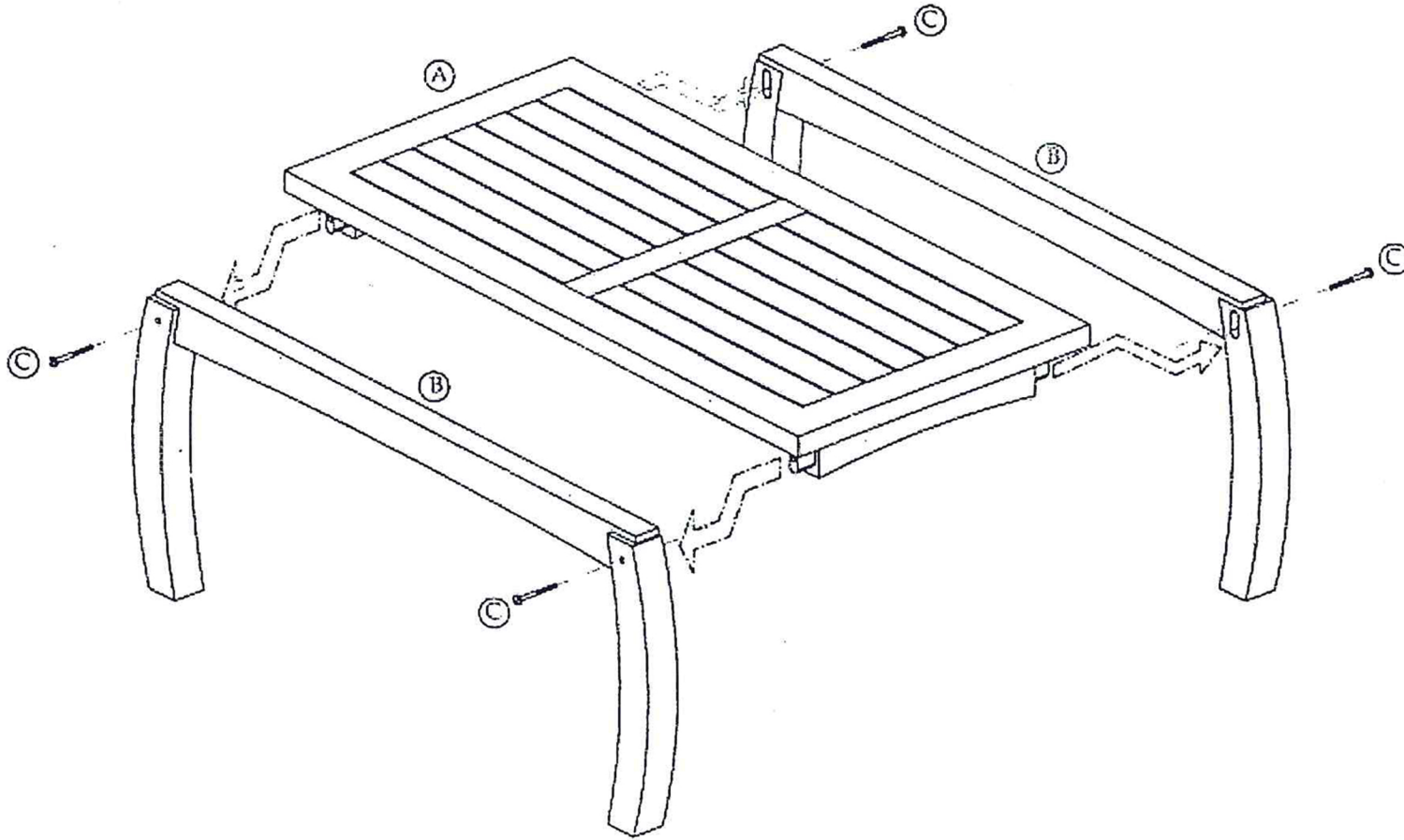


Step 3 : Please install the other leg to step 2



Step 4 : Please instal the dowels to hole that available.





KINTAMANI COFFE TABLE 50X100X45 CM

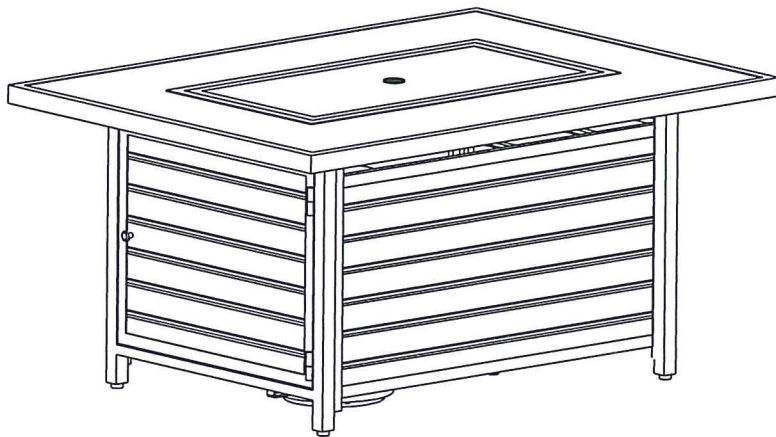
QG-TK021

← 100   
 | 45   
 ↘ 50   
 m<sup>3</sup> 0.07   
 ( cm )

# Stained-Wood-Look Rectangle Aluminum LPG Fire Pit

Item#: 63964

**\*ELECTRONIC IGNITER!**  
*Requires AAA Battery (not included)*



## Installation Precaution

This fire pit requires a minimum 18 inches of cross-ventilation in all directions.  
Failure to provide proper ventilation can void the warranty.



### **ATTACH YOUR RECEIPT HERE**

Keep a copy of your proof of purchase or order confirmation which will be needed if you need to contact us about warranty coverage.

Purchase Date: \_\_\_\_\_

### **WARNING FOR YOUR SAFETY**

1. Improper installation, adjustment, alteration, service or maintenance can cause injury or property damage.
2. Read the installation, operation, and maintenance instructions thoroughly before installing or servicing this equipment.
3. Failure to follow these instructions could result in fire or explosion, which could cause property damage, personal injury, or death.

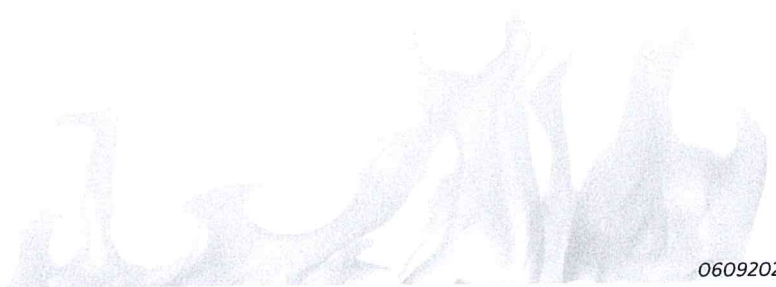
### **WARNING**

For Outdoor Use Only

### **WARNING**

This product can expose you to chemicals including Carbon Monoxide, Lead, Chromium (hexavalent compounds), Di(2-ethylhexyl) phthalate (DEHP) and Diisononyl phthalate (DINP), which are known to the State of California to cause cancer and birth defects or other reproductive harm. For more information, go to [www.P65Warnings.ca.gov](http://www.P65Warnings.ca.gov).

Conforms to ANSI STD Z21.97-2017,  
Certified to CSA STD 2.41-2017 Outdoor decorative gas appliances



## TABLE OF CONTENTS

Before You Begin	Page 2
Package Contents	Page 3
Safety Information	Page 4
Assembly	Pages 5-7
Operating Instructions	Pages 8-11
Conversion to Natural Gas	Pages 12-14
Care and Maintenance	Page 15
Troubleshooting	Page 16
Warranty Information	Page 17

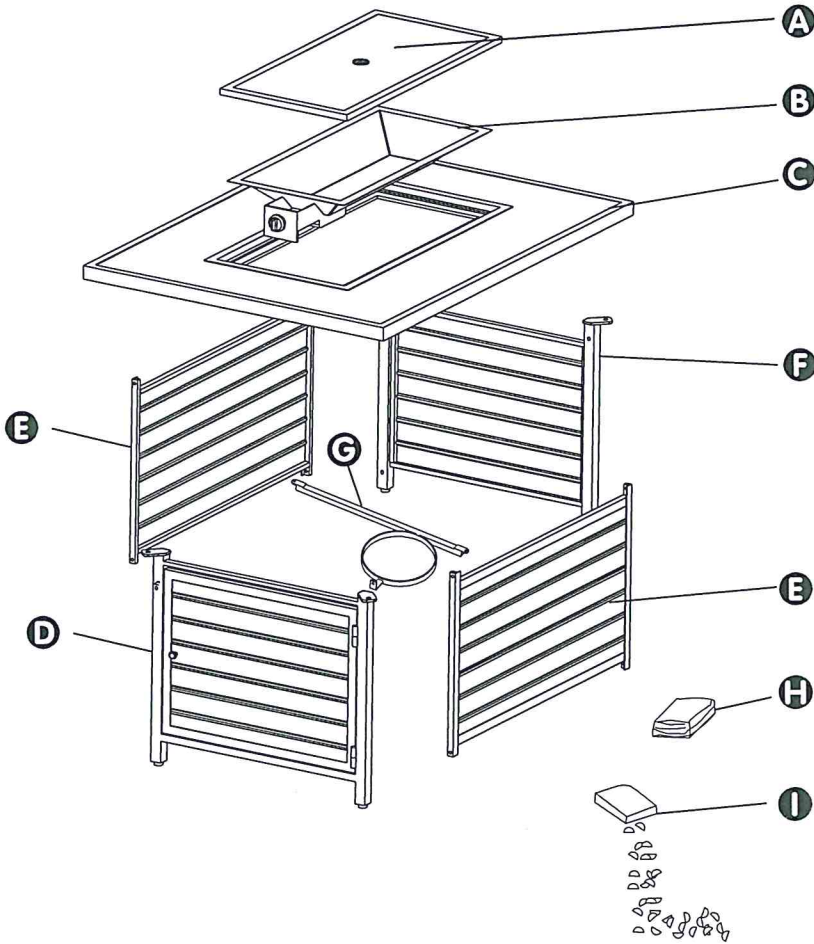


### BEFORE YOU BEGIN

Please read and understand this entire manual before attempting to assemble, operate or install this appliance. If you have any questions regarding the product, please contact your retailer.

This manual contains important information about the assembly, operation and maintenance of this LPG fire pit. General safety information is presented in the first few pages and is also located throughout this manual. Keep this manual for future reference and to educate new users of this appliance.

# PACKAGE CONTENTS

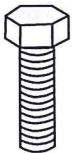


PART	DESCRIPTION	QUANTITY
<b>A</b>	Removable Burner Cover	1
<b>B</b>	Burner	1
<b>C</b>	Table Top	1
<b>D</b>	Front Door Panel	1
<b>E</b>	Side Panels	2
<b>F</b>	Back Panel	1
<b>G</b>	Gas Tank Support	1
<b>H</b>	Protective Cover	1
<b>I</b>	Fire Glass	1

Also required but not included:  
AAA Battery (install by unscrewing igniter button)



## HARDWARE CONTENTS

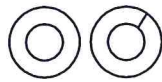


**L**

Bolt 8x20mm

Qty: 5

(4 for assembly +1 extra)



**M**

Washer, Spring Washer 8mm

Qty: 5

(4 for assembly +1 extra)



**N**

Bolt 6x25mm

Qty: 9

(8 for assembly +1 extra)



**O**

Bolt 6x18mm

Qty: 4

(3 for assembly +1 extra)



**P**

Washer 6mm

Qty: 12

(11 for assembly +1 extra)



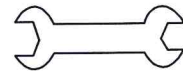
**Q**

Plastic Cap (M8)

Qty: 4



## TOOLS



**R**

Wrench



**S**

Hex Key

# SAFETY INFORMATION

## SAFETY INFORMATION

This appliance has been tested to and complies with the ANSI Z21.97-2017, Outdoor Decorative Gas Appliances CGA CR 97-003 Outdoor Gas Fireplaces. The installation must conform to local codes or in the absence of local codes to the National Fuel Gas Code, ANSI Z223.1. This manual contains important information about the assembly, operation and maintenance of this fire pit. General safety information is presented in these first few pages and is also located throughout the manual. Keep this manual for future reference and to educate new users of this product. This manual should be read in conjunction with the labeling on the product. Safety precautions are essential when any mechanical or propane fueled equipment is involved. These precautions are necessary when using, storing, and servicing. Using the equipment with the respect and caution demanded will reduce the possibilities of personal injury or property damage. The following symbols (shown below) are used extensively throughout this manual. Always heed these precautions, as they are essential when using any mechanical or propane fueled equipment.

## WARNING

Failure to comply with the precautions and instructions provided with this fire pit can result in death, serious bodily injury and property loss or damage from hazards of fire, explosion, burn, asphyxiation, and/or carbon monoxide poisoning. Only persons who can understand and follow the instructions should use or service this fire pit.

## WARNING / DANGER

WARNING/DANGER indicates an imminently hazardous situation which, if not avoided, will result in death or serious injury.

## WARNING

Do not store or use gasoline or other flammable vapors and liquids in the vicinity of this or any other appliance. An LP-cylinder not connected for use shall not be stored in the vicinity of this or any other appliance.

## WARNING

Solid fuels shall not be burned in this appliance.

## DANGER

### EXPLOSION—FIRE HAZARD

- Keep solid combustibles, such as building materials, paper, or cardboard a safe distance away from the fire pit as recommended by the instructions.
- Provide adequate clearances around air openings into the combustion chamber. Never use the fire pit in spaces which do or may contain volatile or airborne combustibles, or products such as gasoline, solvents, paint thinner, dust particles, or unknown chemicals.
- During operation, this appliance can be a source of ignition. Keep fire pit area clear and free from combustible materials, gasoline, paint thinner, cleaning solvents and other flammable vapors and liquids. Do not use fire pit in areas with high dust content. Minimum fire pit clearances from combustible materials: 2 feet (24 inches) from the sides & 2 feet (24 inches) from the rear, 6 feet (72 inches) from ceiling.
- Never store propane near high heat, open flames, pilot lights, direct sunlight, other ignition sources or where temperatures exceed 120 degrees F (49 degrees C).
- Propane vapors are heavier than air and can accumulate in low places. If you smell gas, leave the area immediately.
- Never install or remove a propane cylinder while the fire pit is lighted, or near flame, pilot lights, or other ignition sources or while fire pit is hot to the touch.
- This fire pit is red hot during use and can ignite flammables too close to the burner. Keep flammables at least 6 feet (72 inches) from top and 2 feet (24 inches) from sides. Keep gasoline and other flammable liquids and vapors well away from fire pit.
- Store the propane cylinder outdoors in a well ventilated space out of the reach of children. Never store the propane cylinder in an enclosed area (house, garage, etc.). If fire pit is to be stored indoors, disconnect the propane cylinder for outdoor storage.

## WARNING

- This fire pit is fueled by propane gas. Propane gas is invisible, odorless, and flammable. An odorant is normally added to help detect leaks and can be described as having a "rotten egg" smell. The odorant can fade over time so leaking gas is not always detectable by smell alone.
- Propane gas is heavier than air and leaking propane will sink to the lowest level possible. It can ignite by ignition sources including matches, lighters, sparks, or open flames of any kind many feet away from the original leak. Use only propane gas set up for vapor withdrawal.
- Store or use propane gas in compliance with local ordinances and codes or with ANSI/NFPA 58. Turn off propane when not in use.

## DANGER

### FOR YOUR SAFETY

If you smell gas:

1. Shut off gas to the appliance.
2. Extinguish any open flame
3. If odor continues, keep away from the appliance and immediately call your gas supplier or fire department.

## WARNING

We cannot foresee every use which may be made of our fire pit. Check with your local fire safety authority if you have questions about fire pit use. Other standards govern the use of fuel gases and heat producing products for specific uses. Your local authorities can advise you about these. If no local codes exist, follow National Fuel Gas Code, ANSI Z223.1. In Canada, installation must conform to local codes. If no local codes exist, follow the current National standards of CANADA CAN/CGA-B 149.2.

## WARNING: FOR OUTDOOR USE ONLY

### CARBON MONOXIDE HAZARD

- This fire pit is a combustion appliance. All combustion appliances produce carbon monoxide (CO) during the combustion process. This product is designed to produce extremely minute, non-hazardous amounts of CO if used and maintained in accordance with all warnings and instructions. Do not block air flow into or out of the fire pit.
- Carbon Monoxide (CO) poisoning produces flu-like symptoms, watery eyes, headaches, dizziness, fatigue and possibly death. You can't see it and you can't smell it. It's an invisible killer. If these symptoms are present during operation of this product get fresh air immediately!
- For outdoor use only. Using this fire pit in an enclosed space can kill you. Never use this fire pit in an enclosed space such as a camper, tent, home, or other unventilated or enclosed area.
- This fire pit consumes air (oxygen). Do not use in unventilated or enclosed areas to avoid endangering your life.



## WARNING

Improper installation, adjustment, alteration, service or maintenance can cause property damage, injury or death. Read the installation, operation and maintenance instructions thoroughly before installing or servicing this equipment.

# ASSEMBLY



## PREPARATION

Before beginning assembly, be sure to empty contents of carton and make sure all parts are present. If any parts are missing, please contact the retailer.

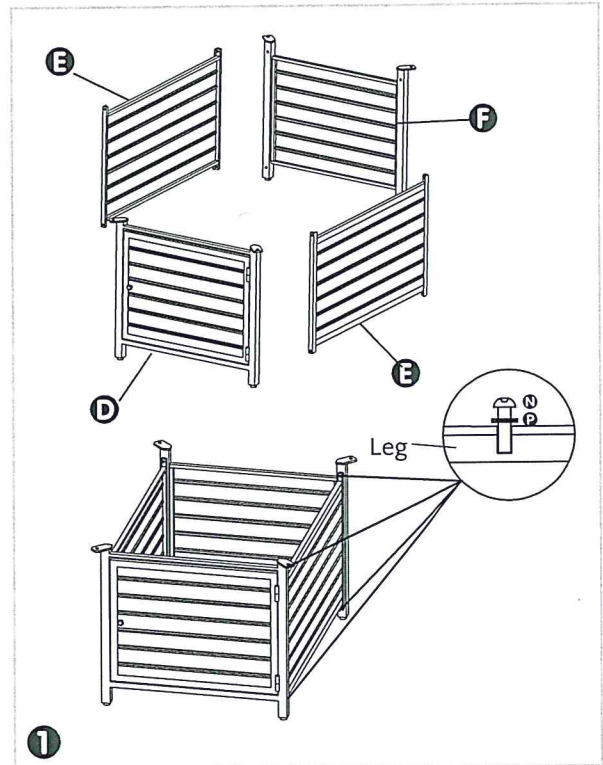
Place all parts on a soft, level surface for assembly. NOTE: it is recommended to use TWO PEOPLE to assemble this gas fire pit. Estimated assembly time: 60 minutes. | Do NOT overtighten hardware!

**1** Locate 4 Panels **D/E/F**. NOTE: There is a hole at the bottom of each Side Panel **E**. The hole should face DOWN.

Place a Washer **P** on each of 8 Bolts **N** and insert through holes in sides of Side Panels into the holes in sides of Leg Panels **D/F**.

Tighten all Bolts **N** with Hex Key **S**.

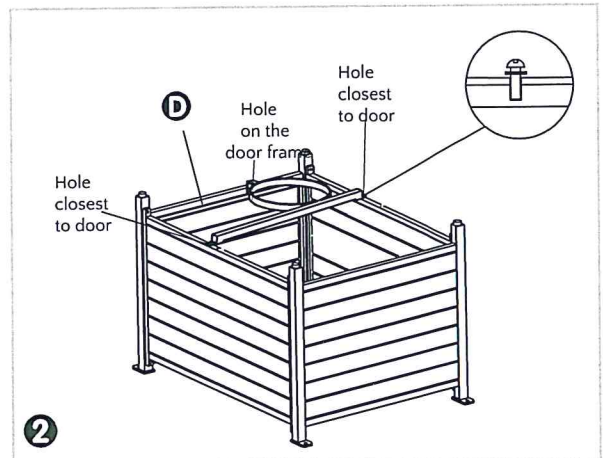
Hardware: **N** Bolt (6x25mm) x 8  
**P** Washer (6mm) x 8



**2** Once all Panels are bolted together, carefully turn the table base upside-down. Attach Gas Tank Support **G** to Side Panels **E** by aligning holes in Gas Tank Support with holes in the bottom of Side Panels and Door.

Place a Washer **P** on each of 2 Bolts **G** and insert into aligned holes. Tighten with Hex Key **S**.

Hardware: **G** Bolt (6x18mm) x 2  
**P** Washer (6mm) x 8





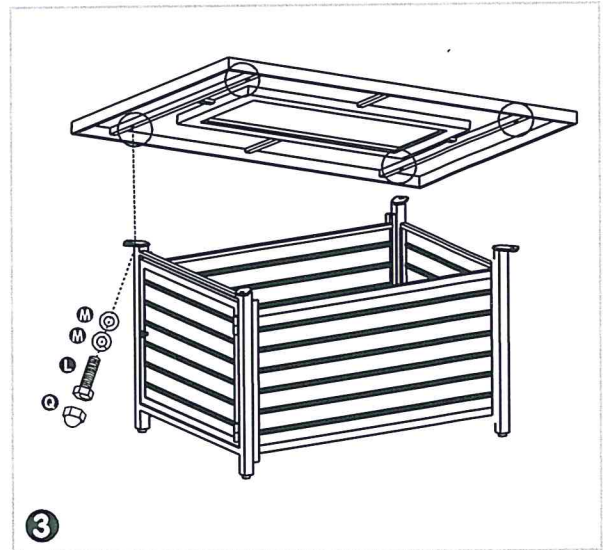
## ASSEMBLY

**3** Turn the assembled table base upright, then place **Table Top** **C** over **Legs**, and align the holes on **Table Top** with holes at the top of **Legs**. Place **Spring Washer** **M**, then **Washer** **N** on each of 4 **Bolts** **L**, then insert into the aligned holes. Tighten with **Wrench** **R**, then cover bolt heads with **Plastic Caps** **O**.

Hardware:     **L** Bolt (8x20mm) x 4  
                  **M** Washer/Spring Washer (8mm) x 4t  
                  **O** Plastic Cap x 4

**WARNING:**

*This fire pit is constructed of aluminum, a relatively soft, flexible metal. Do not sit, stand, or lean heavily on the top of the fire pit, which can cause bending or warping.*



**4** Place the **Burner** **B** into the hole in the **Table Top** **C**. Make sure the Control Knob on the **Burner** faces the **Front Door Panel** **D**.

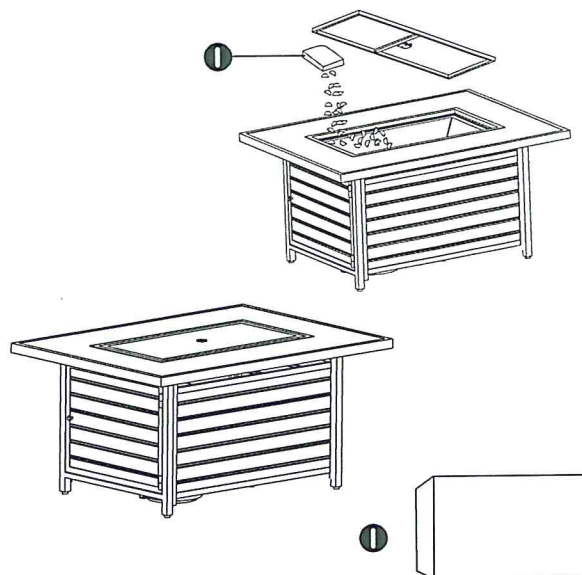
Unscrew the igniter button and insert a AAA Battery with positive end facing out. Screw the button back onto the control panel.



## ASSEMBLY

- 5** Pour the **Fire Glass ①** around the **Burner**. Be careful not to obstruct pilot light housing. Put the **Removable Burner Cover ②** on the **Burner**.

When the fire pit is NOT in use, or after use, when the fire pit has cooled COMPLETELY, cover it with the **Protective Cover ③**. DO NOT PUT THE PROTECTIVE FIRE PIT COVER ON A HOT FIRE PIT.

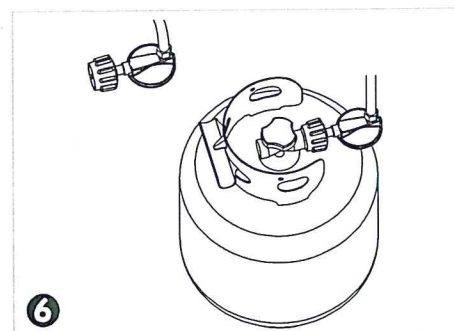
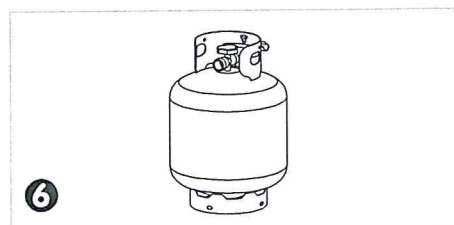


- 6** Connect hose and regulator to cylinder. The propane gas and cylinder are sold separately. Use a standard 20lb propane cylinder only. Use this fire pit only with a propane vapor withdrawal supply system. See chapter 5 of the standard storage and handling of liquefied petroleum gas, ANSI/NFPA 58. Your local library or fire department should have this book.

Storage of an appliance indoors is permissible only if the cylinder is disconnected and removed from the appliance. A cylinder must be stored outdoors in a well-ventilated area out of the reach of children. A disconnected cylinder must have dust caps tightly installed and must not be stored in a building, garage or any other enclosed area. The maximum inlet gas supply pressure: 250 PSI, the minimum inlet gas supply pressure: 5 PSI.

for automatic operation at ratings less than full input rating. The pressure regulator and hose assembly supplied with the appliance must be used.

The installation must conform with local codes, or in the absence of local codes, with national fuel gas code, ANSI Z223.1/NFPA54, natural gas and propane Installation Code, CSA B 149.1, or propane storage and handling code, B149.2.



## OPERATING INSTRUCTIONS

A dented, rusted or damaged propane cylinder may be hazardous and should be checked by your cylinder supplier. Never use a propane cylinder with a damaged valve connection.

The propane cylinder must be constructed and marked in accordance with the specifications for LP gas cylinders of the U.S. Department of Transportation (DOT) or the standard for cylinders, spheres and tubes for transportation of dangerous goods and commission, CAN/CSA-B339.

The cylinder must have a listed overfilling prevention device.

The cylinder used must include a collar to protect the cylinder valve.

Never connect an unregulated propane cylinder to the fire pit.

Attach regulator to cylinder. Complete attachment. Install cylinder.

- Do not store a spare LP gas cylinder under or near this appliance;
- Never fill the cylinder beyond 80 percent full;
- Place the dust cap on the cylinder valve outlet whenever the cylinder is not in use. Only install the type of dust cap on the cylinder valve that is provided with the cylinder valve. Other type of caps or plugs may result in leakage of propane.

**ATTENTION: THIS PRODUCT IS NOT FOR COMMERCIAL USE. IT IS INTENDED FOR RESIDENTIAL USE ONLY.**

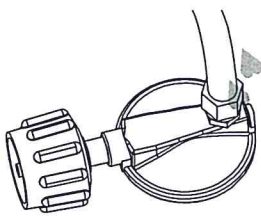
- Do not sit or stand on this table.
- Keep children away during assembly. This item contains small parts which can be swallowed by children.
- Do not use indoors or inside any enclosure.
- Retain the assembly instructions for future reference.
- Installer – please leave these instructions with the owner.

# OPERATING INSTRUCTIONS

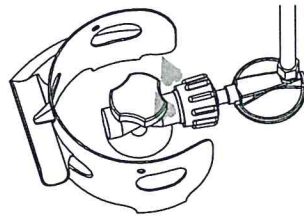
## LEAK CHECK

### ⚠ WARNING!

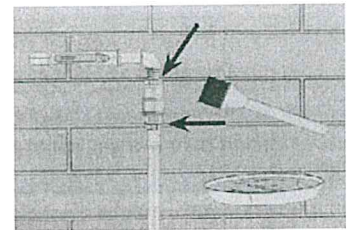
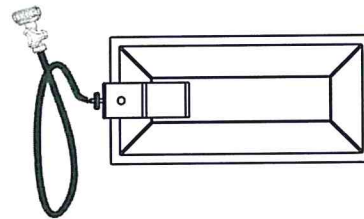
- Perform all leak tests outdoors.
- Extinguish all open flames.
- NEVER leak test when smoking.
- Do not use the fire pit until all connections have been leak tested and do not leak.



Hose / Regulator  
Connection



Regulator / Cylinder  
Connection



1. Make 2-3 oz. of leak test solution (one part liquid dishwashing detergent and three parts water).
2. Apply several drops of solution where hose attaches to regulator.
3. Apply several drops of solution where regulator connects to cylinder.
4. Make sure all valves are turned OFF.
5. Turn cylinder valve ON.

**If bubbles appear at any connection there is a leak.**

1. Turn cylinder valve OFF.
2. If leak is at hose/regulator connection: tighten connection and perform another leak test. If bubbles continue appearing, the hose should be returned to the place of purchase.
3. If leak is at regulatory/cylinder valve connection: disconnect, reconnect, and perform another leak test. If you continue to see bubbles after several attempts, cylinder valve is defective and should be returned to cylinder's place of purchase.

**If NO bubbles appear at any connection, the connections are secure.**

**NOTE: Whenever gas connections are loosened or removed, you must perform a complete leak test. Complete installation.**

# OPERATING INSTRUCTIONS

## CAUTION

Do not attempt to operate until you have read and understand all General Safety Information in this manual, all assembly is complete, and leak test has been performed.

### DANGER!

#### FOR OUTDOOR USE ONLY

##### CARBON MONOXIDE HAZARD

Never use this inside a house or other unventilated or enclosed areas. This fire pit consumes air (oxygen). Do not use in unventilated or enclosed areas to avoid endangering your life.

### WARNING

#### Very hot while in operation!

Never lean over the fire pit while in use. Do not touch Table Top or burner Assembly while the fire pit is in operation. Fire pit will be hot after use. Handle with care. Wait until fire pit has cooled down after use before placing lid on Table Top or touching any surfaces. Failure to follow these instructions may result in serious bodily injury.

### WARNING

#### FOR YOUR SAFETY

Be careful when attempting to manually ignite this fire pit. Holding in the control knob for more than 10 seconds before igniting the gas will cause a ball of flame upon ignition.



## OPERATION CHECKLIST:

For a safe and pleasant heating experience, review this checklist before each use:

- I am familiar with entire owner's manual and understand all precautions noted.
- All components are properly assembled, intact, and operable.
- No alterations have been made.
- All gas connections are secure and do not leak.
- Wind velocity is below 10mph.
- I understand the unit will operate at reduced efficiency below 40°F.
- I understand the fire pit is for outdoor use (outside any enclosure).
- There is adequate fresh air ventilation.
- Fire pit is away from gasoline and other flammable liquids or vapors.
- Fire pit is away from windows, air intake openings, sprinklers, and other water sources.
- Fire pit is at least two (2) feet on all sides/front/back and six (6) feet overhead from combustible materials.
- Fire pit is on a hard and level surface.
- There are no signs of spider/insect nests in fire pit orifices.
- All burner passages and air circulation passages are clear.
- I understand children and adults should be alerted to the hazard of high surface temperatures and should stay away to avoid burns or clothing ignition.
- I understand young children should be carefully supervised when they are in the area of the fire pit.
- I understand clothing or other fabric material should not be hung from the fire pit or placed on or near the fire pit.
- I understand that any guard or other protective device removed for servicing the fire pit must be replaced prior to operating the fire pit.
- I understand installation and repair should be done by a qualified service person, and that the fire pit should be inspected before each use and at least annually by a qualified service person.
- I understand that more frequent cleaning may be required as necessary and that it is imperative that the control compartment, burner, and circulating air passageways of the fire pit be kept clean.
- The fire pit is constructed of aluminum, a relatively soft/flexible metal, and I should not allow anyone to sit or lean heavily on the top of the fire pit, which can cause bending or warping.



## BEFORE TURNING GAS SUPPLY ON:

1. Your fire pit was designed and approved for outdoor use only. Do NOT use it inside a building, garage, or any other enclosed area.
2. Make sure surrounding areas are free of combustible materials, gasoline, and other flammable vapors or liquids.
3. Ensure that there is no obstruction to air ventilation. Be sure all gas connections are tight and there are no leaks.
4. Be sure the cylinder is clear of debris. Be sure any component removed during assembly or servicing is replaced and fastened prior to starting.

# OPERATING INSTRUCTIONS

**NOTE:** This model has an Electronic Igniter and requires one AAA battery. Unscrew IGNITER BUTTON to install.



Electronic igniter requires AAA battery

**⚠ DANGER!**  
**FOR OUTDOOR USE ONLY**

**⚠ CARBON MONOXIDE HAZARD**

Never use this fire pit inside a house or other unventilated or enclosed areas. This fire pit consumes air (oxygen). Do not use in unventilated or enclosed areas to avoid endangering your life.

## BEFORE LIGHTING:

1. Smell all around the unit area for gas. Be sure to smell near the floor, because gas is heavier than air and will settle to the lowest point. If you smell gas, shut off the gas to the appliance, extinguish any open flame, and if odor persists, call your gas supplier or the fire department.
2. Fire pit should be thoroughly inspected before each use, and by a qualified service person at least annually. If relighting a hot fire pit, always wait at least 5 minutes.
3. Inspect hose assembly for evidence of excessive abrasion, cuts, or wear. Suspect areas should be leak tested. If the hose leaks, it must be replaced prior to operation. Only use the replacement hose assembly specified by manufacturer.

## LIGHTING:

**NOTE:** Use only your hand to depress or turn the gas control knob. Never use tools. If the knob will not depress or turn by hand, DO NOT try to repair it. Call a qualified professional service technician. Force or attempted repair may result in fire or explosion and will void the warranty.

1. Turn the control knob to "OFF" position (Fig. A).
2. Fully open LP cylinder valve. **Note: For initial start or after any cylinder change, hold Control Knob IN for 2 minutes to purge air from gas lines before proceeding.**
3. Push in and turn the control knob counterclockwise to HIGH (Fig. B).
4. While holding control knob in, push the Electronic Ignition button to ignite the main burner. (The ignition will produce a soft snapping/crackling sound. If the fire pit does not light and there is no snapping sound, replace the battery.)
5. After fire pit lights, wait 45 seconds, then release control knob.
6. Observe the flame height when lit. Flame should reach between 3 and 13 inches in height. Overly short or tall flame can indicate a problem.
7. To decrease the flame, turn the control knob clockwise to LOW (Fig. C). To increase the flame, turn the control knob counterclockwise to HIGH (Fig. B).

**NOTE:** If burner fails to remain lit, close all valves and wait at least 5 minutes before attempting to light.

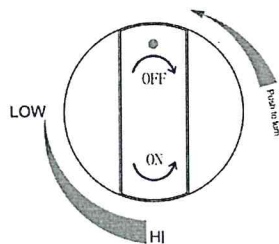
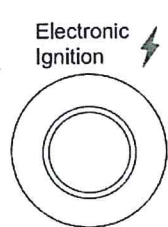


Figure A

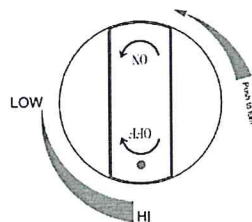


Figure B

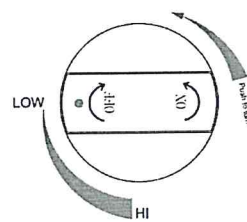
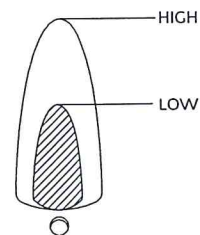


Figure C



## SHUT DOWN:

1. To extinguish burner depress control knob and turn it clockwise to OFF.
2. Turn cylinder valve clockwise to OFF and disconnect regulator when fire pit is not in use.

## AFTER-OPERATION CHECKLIST:

1. Gas control knob is in OFF position.
2. Gas tank valve is OFF.
3. Gas line is disconnected.

## CONVERSION TO NATURAL GAS

### WARNING

Make sure all control knobs and cylinder valves are in OFF position before converting.

This appliance is portable and configured for use with Liquid Propane (LP Gas), which is delivered via removable tanks (LP tanks and their use are covered elsewhere in this manual). If a Natural Gas connection is available, the user may wish to change the gas delivery system to the more permanent Natural Gas Supply.

This appliance is certified for use with either Liquid Propane (LP Gas) or Natural Gas and comes complete with the necessary parts to convert the appliance for use with Natural Gas. A Natural Gas hose and regulator are also required and are sold separately. The conversion valves allow the use of Natural Gas without replacing the burners or entire valve system.

The process of converting the burner from Propane to Natural Gas is relatively simple and can be accomplished by any handy homeowner. We recommend, however, that a qualified gas technician do the conversion. Your warranty may be voided if the conversion is improperly completed. Please retain the parts supplied with the appliance and these instructions so the technician can do the conversion.

#### Orifice Chart

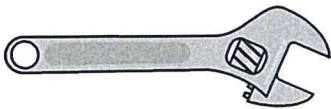
The different burner valves in this appliance have different BTU ratings. The holes in the orifices are drilled to different sizes so as to allow the proper amount of gas to flow through them. Please note the chart below to give an easy reference for the various orifice opening sizes for the different valves in the appliance.

Propane (Pressure 11")		NG (Pressure 7")	
Orifice Size	Input Rate (BTU/h)	Orifice Size	Input Rate (BTU/h)
2.3mm	55,000	3.78mm	55,000

#### NG Hose and Regulator Conversion

##### Tools Required:

- Adjustable Wrench (2)



### WARNING

Make sure all appliance components are completely cooled and gas supply is turned off and removed from the appliance prior to performing the conversion.

## CONVERSION TO NATURAL GAS

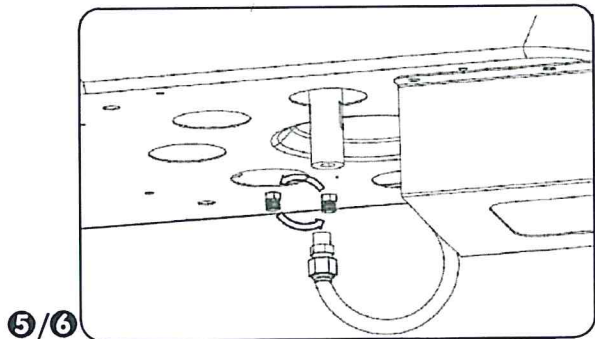
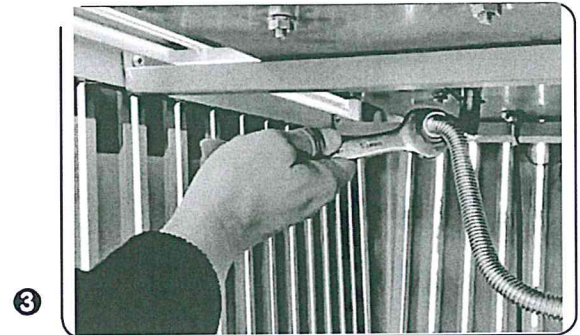
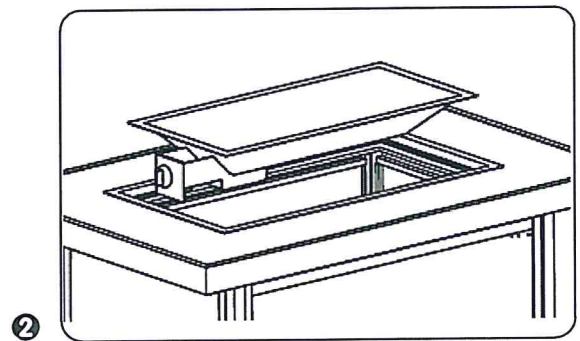
**⚠️ WARNING!** To avoid the possibility of burns conversion should only be done when the patio flame. Ensure burner is turned off. Turn gas off at source and disconnect the appliance before beginning conversion.

**⚠️ WARNING!** Fire Glass may have sharp edges. Wear safety glasses and gloves when handling.

**⚠️ WARNING!** We recommend that the conversion be performed by a licensed gas fitter, and all connections must be leak tested prior to operating the appliance.

Your fire pit can be easily converted for Natural Gas by following these steps:

1. If desired, remove the Burner from the enclosure. (Remove the Fire Glass from the Burner first.) Take care not to damage or kink the **Thermocouple Wire**. Alternatively, you may wish to perform the conversion from below via the **Tank Access Door**.
2. Disconnect the stainless steel **Flex Line** from the brass **Connector Valve** using two Wrenches.
3. Unscrew the **Connector Valve** from the **Burner Pipe**.
4. Slide the **Air Shutter** tube included in the conversion kit onto the **Burner Pipe**, covering the vent screens.
5. Remove the small brass **Propane Orifice** from the burner end of the **Connector Valve**.
6. Replace the **Propane Orifice** with the **Natural Gas Orifice** supplied. Fully tighten with Wrench for a secure seal.
7. Screw the **Connector Valve** back into the **Burner Pipe**. Fully tighten with Wrench for a secure seal.
8. Re-attach **Flex Line** to **Connector Valve**. Fully tighten with Wrenches for a secure seal.
9. Place **Burner** back into enclosure if you removed it.
10. Place the **Conversion Label** included with your **Conversion Kit** on the inside of the **Tank Access Door**.
11. Replace the existing LPG hose and regulator with an NG regulator and hose (not included).
12. **Connect your gas supply and perform a Leak Test at each connection point.** Leak Test instructions are found elsewhere in this manual.





## CONVERSION TO NATURAL GAS

### Natural Gas Hook-Up

The gas appliance is designed to operate at an inlet pressure of 7 inches water column. The piping up to the appliance is the responsibility of the installer. Connect the inlet valve to rigid pipe, copper tube or an approved flexible metal connector, which complies with Z21.4/CSA 6.10. If using a gas hose (not supplied) connect the flared end of the hose to the connector on the end of the inlet valve. Tighten using two wrenches. (Do not use thread sealer/pipe dope.) Leak test all joints prior to using the appliance. Piping and valves upstream of the quick disconnect are not supplied. The gas supply pipe must be sufficiently sized to supply the BTU/h specified on the rating plate, based on the length of the piping run. The quick disconnect must not be installed in an upward direction and a readily accessible manual shut-off valve must be installed upstream of, and as close to, the quick disconnect as is feasible.

**Purge the gas supply line of any trapped air prior to the first firing of the unit.**

#### **WARNING!**

- The installation must be performed by a licensed gas fitter, and all connection must be leak tested before operating the appliance.
- Ensure all hose connections are tightened using two wrenches. Do not use Teflon tape or pipe dope on any hose connection.
- Ensure the hose does not contact any high temperature surfaces or it may melt and leak causing a fire.
- Locate the hose away from pathways where people may trip over it and areas where the hose may be subject to accidental damage.
- Leak test all the connections using a soap and water solution as per the leak testing instructions found in the manual.

## CARE & MAINTENANCE

To enjoy years of outstanding performance from your fire pit, make sure you perform the following maintenance activities on a regular basis:

1. Use warm soapy water for cleaning. Never use flammable or corrosive cleaning agents.
2. While cleaning your unit, be sure to keep the area around the burner and control compartment dry at all times. Do not submerge the control valve assembly. If the gas control is submerged in water, do NOT use it. It must be replaced. Make sure fire pit has cooled completely before cleaning or covering with a cover.
  - A. Keep the appliance area clear and free from combustible materials, gasoline and other flammable vapors and liquids.
  - B. Do not obstruct the flow of combustion and ventilation air.
  - C. Keep the ventilation opening(s) of the cylinder enclosure free and clear from debris.
3. Air flow must be unobstructed. Keep controls, burner, and circulating air passageways clean. Signs of possible blockage include:
  - Gas odor with extreme yellow tipping of flame.
  - Fire pit does NOT reach the desired temperature.
  - Fire pit glow is excessively uneven.
  - Fire pit makes popping noise.
  - Spiders and insects can nest in burner or orifices. This dangerous condition can damage fire pit and render it unsafe for use. Clean burner holes by using a heavy-duty pipe cleaner. Compressed air may help clear away smaller particles.
  - Carbon deposits may create a fire hazard. Clean burner screen with warm soapy water if any carbon deposits develop.



Note: In a salt-air environment (such as near an ocean), corrosion occurs more quickly than normal. Frequently check for corroded areas and repair them promptly.

### SERVICE:

Only a qualified service person should repair gas passages and associated components.



### WARNING

#### FOR YOUR SAFETY

- Do NOT touch or move fire pit for at least 45 minutes after use.
- Burner is hot to the touch.
- Allow burner to cool before touching.

### STORAGE:

#### Between uses:

- Turn control knob OFF.
- Disconnect LP source.
- Store fire pit in an area sheltered from direct contact with inclement weather (such as rain, sleet, hail, snow, dust and debris).
- If desired, cover fire pit to protect exterior surfaces and to help prevent build-up in air passages.

#### During periods of extended inactivity or when transporting:

- Turn control knob OFF.
- Disconnect LP source and move to a secure, well-ventilated location outdoors.
- Store fire pit in an area sheltered from direct contact with inclement weather (such as rain, sleet, hail, snow dust and debris).
- If desired, cover fire pit to protect exterior surfaces and to help prevent build-up in air passages. Never leave LP cylinder exposed to direct sunlight or excessive heat.

**Note:** Wait until fire pit is cool before covering.

**Caution:** Always allow fire pit to cool before attempting service.

## TROUBLESHOOTING

PROBLEM	POSSIBLE CAUSE	CORRECTIVE ACTION
Burner will not light	Propane cylinder is frosted over	Wait until the propane cylinder warms up and becomes unfrosted
	Blockage in orifice	Clear blockage
	Control knob is not in ON position	Turn control knob to ON
Burner flame is low	Gas pressure is low	Turn cylinder valve OFF and replace cylinder
	Outdoor temperature is less than 40°F and tank is less than 1/4 full	Use a full cylinder
	Control knob fully ON	Check burner and orifices for blockage
Carbon build-up Thick Black Smoke	Dirt or film on burner screen	Clean burner screen
	Blockage in burner	Remove blockage and clean burner screen inside and outside.



## **1 YEAR LIMITED WARRANTY – Customers in the Contiguous US**

All components are warranted for a period of 1 year after date of purchase by the original owner against defects in materials and workmanship under normal use. This warranty does NOT cover normal wear and weathering, assembly and/or maintenance OR use in a commercial application if model is not designated as a commercial model. At the manufacturer's sole discretion, products under warranty will be repaired and/or replaced at no charge to the customer. Any returns sent back to the manufacturer must be sent via prepaid freight and in the original retail packaging.

This warranty is extended only to the original purchaser. Proof of purchase will be required before warranty service is rendered. The sales receipt is the only valid proof of purchase. This warranty only covers failures due to defects in materials or workmanship which occur during normal use. Failures and/or damage which result from accident, negligence, misuse, abuse, neglect, mishandling, alteration or modification, failure to maintain, improper assembly or maintenance, service by unauthorized agency or use of unauthorized components or damage that is attributable to acts of God are NOT covered.

**\*\*\*THERE ARE NO EXPRESS WARRANTIES EXCEPT AS LISTED ABOVE\*\*\***

**\*\*\*PURCHASER ASSUMES ALL RISKS IN THE ASSEMBLY AND OPERATION OF THIS UNIT\*\*\***

**\*\*\*FAILURE TO FOLLOW WARNINGS AND OPERATIONAL INSTRUCTIONS CONTAINED IN THIS MANUAL CAN RESULT IN SEVERE PROPERTY DAMAGE AND/OR PERSONAL INJURY\*\*\***

**IN NO EVENT WILL THE MANUFACTURER, OR ITS DIRECTORS, OFFICERS OR AGENTS BE LIABLE TO THE PURCHASER OR ANY THIRD PARTY, WHETHER IN CONTRACT, IN TORT, OR ON ANY OTHER BASIS, FOR ANY INDIRECT, SPECIAL, PUNITIVE, EXEMPLARY, CONSEQUENTIAL, OR INCIDENTAL LOSS, COST, OR DAMAGE ARISING OUT OF OR IN CONNECTION WITH THE SALE, MAINTENANCE, USE, OR INABILITY TO USE THE PRODUCT, EVEN IF THE MANUFACTURER OR ITS DIRECTORS, OFFICERS OR AGENTS HAVE BEEN ADVISED OF THE POSSIBILITY OF SUCH LOSSES, COSTS OR DAMAGES, OR IF SUCH LOSSES, COSTS, OR DAMAGES ARE FORESEEABLE. IN NO EVENT WILL THE MANUFACTURER, OR ITS OFFICERS, DIRECTORS, OR AGENTS BE LIABLE FOR ANY DIRECT LOSSES, COSTS OR DAMAGES THAT EXCEED THE PURCHASE PRICE OF THE PRODUCT.**

**SOME JURISDICTIONS DO NOT ALLOW THE EXCLUSION OR LIMITATION OF INCIDENTAL OR CONSEQUENTIAL DAMAGES, SO THE ABOVE LIMITATION OR EXCLUSION MAY NOT APPLY TO THE PURCHASER.**

This limited warranty gives you specific legal rights and you may also have other rights which vary from jurisdiction to jurisdiction. The provisions of the United Nations Convention on Contracts for the Sales of Goods shall not apply to this limited warranty or the sale of products covered by this limited warranty.